

WARNING

This information is a copy of an original archive, therefore Aga cannot be held responsible for its continued accuracy.

When you buy a **RAYBURN**
REGD.
what a lot you get for your money



*TWO JOBS . . . cooking and water heating
one appliance, one fire, one fuel bill, and
a warm kitchen too!*

WHICHEVER RAYBURN YOU BUY you will get easy cooking. The Rayburn has a large, evenly heated roasting oven (there is a thermometer to guide you). The hotplate is big enough to hold 4 or more large pans, and has deep fins to concentrate and retain the heat; this ensures rapid boiling.

Constant hot water

The Rayburn stays alight night and day—keeps the water piping hot for bath, basin and kitchen sink.

Continuous burning

The Rayburn will burn for 10 hours without attention. So you come down to a warm and cosy kitchen on a cold winter morning.

Small fuel bills

The Rayburn is a miser on fuel. Its average fuel consumption is $1\frac{1}{2}$ - $1\frac{3}{4}$ cwt. a week, and it burns as little as $\frac{1}{2}$ lb. an hour when idling.

Hardly any work

Dustless riddling—a few movements with the riddling handle, with both doors shut, and the job is done. A wipe over with a damp cloth will keep the cream and black vitreous enamel finish bright and sparkling. You only need to re-fuel at the most 3 times a day. And all the ash falls into a fitted ashpan that needs emptying only once a day!

Warm in winter, cool in summer

The Rayburn is an insulated cooker. Keeps your kitchen warm in winter, but won't overheat it during the summer.

The Rayburn is included in the lists of appliances recommended by the Coal Utilisation Council and the Solid Smokeless Fuels Federation.

Which is the model for you!

THE NO. 3 RAYBURN has two ovens, one for warming, and can have a hinged insulating cover to the hotplate. It will cook for 6/8 people comfortably.

THE NO. 1 RAYBURN is slightly smaller, with one large oven, but the same hotplate and hot water performance.

THE NO. 1 WITH LOW-PRESSURE SIDE TANK is designed for houses with no running water. You can draw off up to 12 gallons of really hot water without refilling the tank.

When you have decided on the cooker, please obtain details of installation and the recommended hot water system either from your local merchant or from Allied Ironfounders Ltd.

FACTS AND FIGURES

about the Rayburn cooker and water heater

The fuels we recommend

The Rayburn thrives on economical smokeless COKE, but it will burn quite happily on Anthracite, household coal and manufactured fuels such as "Coalite", "Rexco" or "Phurnacite", even on wood and peat.

U.K. PATENT NO. 666809

Dimensions:—

	No. 1	No. 3
Overall measurements of body	30" wide × 30" high × 20" deep	33" wide × 32" high × 20" deep
Height to top of splash plate	49"	52½"

The makers reserve the right to make alterations to design, materials or construction, for manufacturing or other reasons, subsequent to publication



The Rayburn Cooker is a product of ALLIED IRONFOUNDERS LIMITED Makers of cookers, boilers, fires and baths 28 Brook Street, London, W.1

No. 3 RAYBURN Cooker

Registered Trade Mark

U.K. Patent Nos. 505458 and 666509

Instructions for replacement of a complete set of Fire Bricks

Left Hand Oven Model -- With Boiler

Lift off the Hotplate, no unscrewing being necessary.
Lift out the circular bottom grate (Part No. 146) and withdraw the bottom grate frame (Part No. 145).

Remove the bricks in the following order, 249-9, 254-8, 252-7a, 253-6a, 250-5a, 3.248-4a, 3.251-2a, 3.47-3a.

To assemble replacements into Cooker the order is reversed, starting with 3.47-3a until 249-9 is in position.

Make good joints between fire bricks and between fire bricks and boiler with Fire Cement.

Replace bottom grate frame and bottom grate, making sure the two projections on the rim engage the pin on the end of the riddling bar. (See Working Instructions, Fig. 2.)

When replacing the Hotplate, see that the Asbestos Sealing Rope is in its original position.

Instructions for replacement of bottom Fire Bricks only

Lift out the circular bottom grate (Part No. 146) and withdraw the bottom grate frame (Part No. 145).

Break off all cement joints holding bottom fire bricks 3.248-4a, 3.251-2a and 3.47-3a in position. These bricks can then be removed in this order, leaving top side bricks resting on cast iron flanges which are cast integral with the Sham Cheek and Oven Cheek. This can be done by removing the Hotplate as described above or through the Fire Door opening.

Assemble replacements in the following order, viz., 3.47-3a, 3.251-2a, 3.248-4a.

Replace bottom grate frame and bottom grate, making sure the two projections on the rim engage the pin on the end of the riddling bar. (See Working Instructions, Fig. 2.)

Replacement of Brick 3.248-4a or 3.251-2a only, can be effected without disturbing any other bricks. If replacement of 3.47-3a only is required, then both side bricks 3.251-2a and 3.248-4a must be removed. Replace side bricks and see joints are made good with Fire Cement.

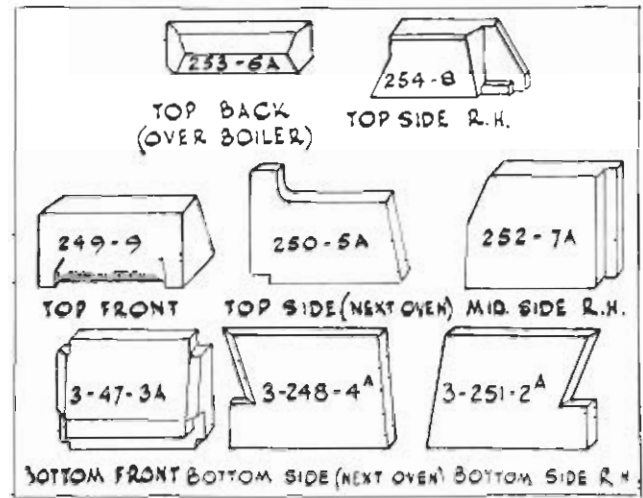

COMPONENT BRICKS

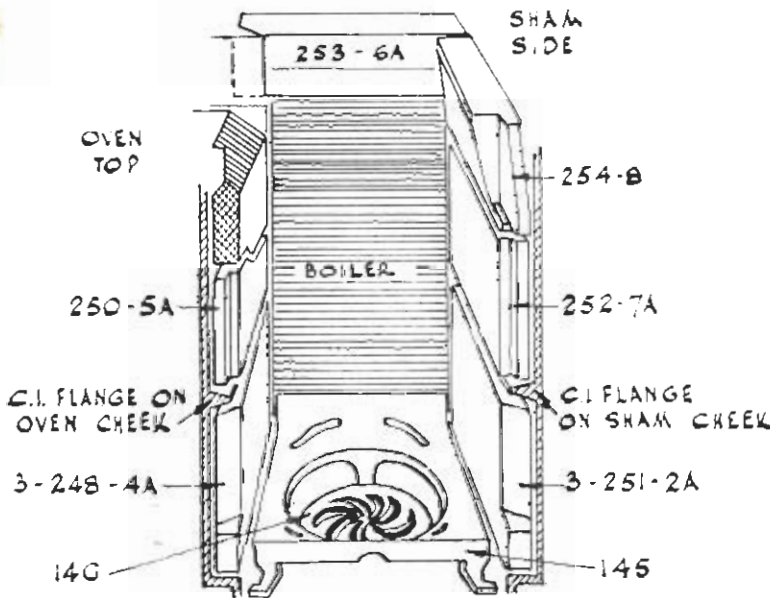

LOOKING FROM FRONT

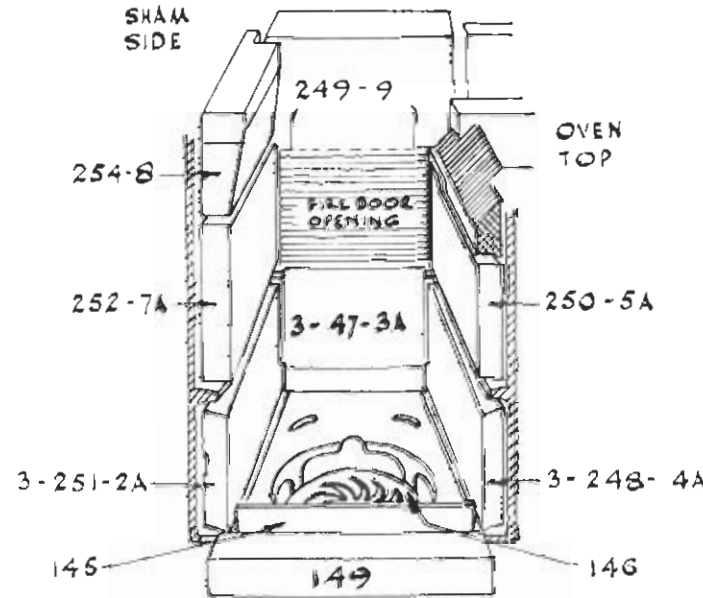

LOOKING FROM BACK

MANUFACTURED BY



REGD TRADE MARK

March 54 I.E.J.D.

THE PLANET FOUNDRY
CO. LTD.

Guide Bridge, Nr. Manchester

THE COALBROOKDALE
CO. LTD.

Wellington, Shropshire

THE FALKIRK IRON
CO. LTD.

Falkirk, Stirlingshire

Proprietors: ALLIED IRONFOUNDERS LTD.

1100165

No. 3 RAYBURN Cooker

Registered Trade Mark

U.K. Patent Nos. 505458 and 666829

Instructions for replacement of a complete set of Fire Bricks

Right Hand Oven Model — With Boiler

Lift off the Hotplate, no unscrewing being necessary. Lift out the circular bottom grate (Part No. 146) and withdraw the bottom grate frame (Part No. 145).

Remove the bricks in the following order, 49-9, 54-8, 52-7a, 53-6a, 50-5a, 3-48-4a, 3-51-2a, 3-47-3a.

To assemble replacements into Cooker the order is reversed, starting with 3-47-3a until 49-9 is in position.

Make good joints between fire bricks and between fire bricks and boiler with Fire Cement.

Replace bottom grate frame and bottom grate, making sure the two projections on the rim engage the pin on the end of the riddling bar. (See Working Instructions, Fig. 2.)

When replacing the Hotplate, see that the Asbestos Sealing Rope is in its original position.

Instructions for replacement of bottom Fire Bricks only

Lift out the circular bottom grate (Part No. 146) and withdraw the bottom grate frame (Part No. 145).

Break off all cement joints holding bottom fire bricks 3-48-4a, 3-51-2a and 3-47-3a in position. These bricks can then be removed in this order, leaving top side bricks resting on cast iron flanges which are cast integral with the Sham Cheek and Oven Cheek. This can be done by removing the Hotplate as described above or through the Fire Door opening.

Assemble replacements in the following order, viz., 3-47-3a, 3-51-2a, 3-48-4a.

Replace bottom grate frame and bottom grate, making sure the two projections on the rim engage the pin on the end of the riddling bar. (See Working Instructions, Fig. 2.)

Replacement of Bricks 3-48-4a or 3-51-2a only, can be effected without disturbing any other bricks.

If replacement of 3-47-3a only, is required then both side bricks 3-51-2a and 3-48-4a must be removed. Replace side bricks and see joints are made good with Fire Cement.

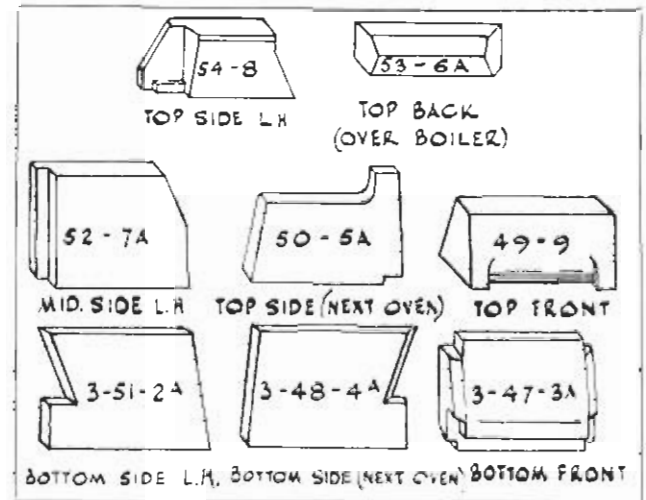

COMPONENT BRICKS

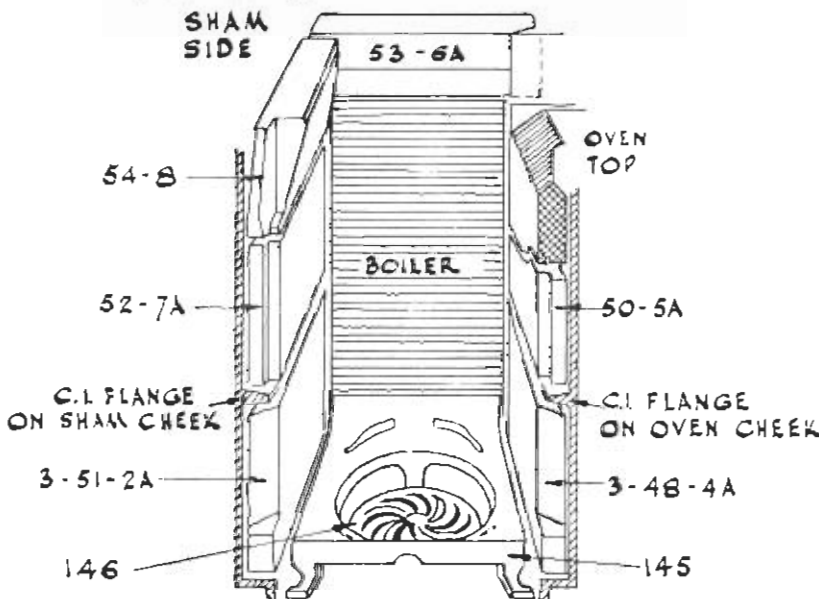

LOOKING FROM FRONT

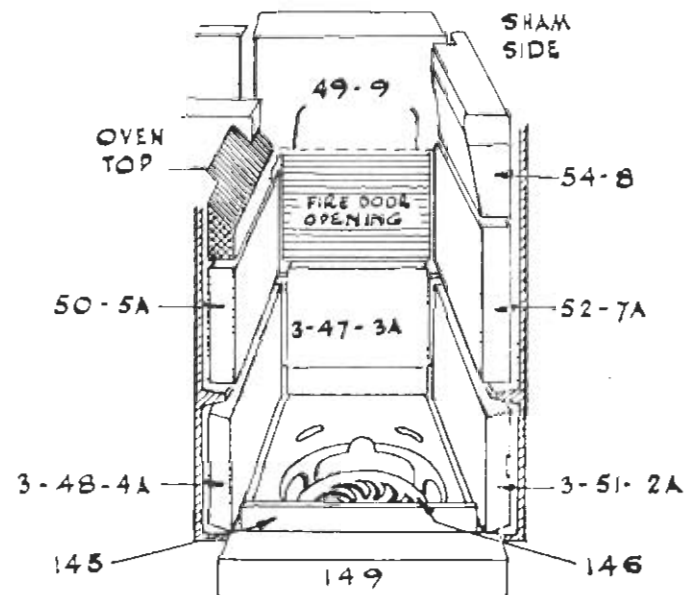

LOOKING FROM BACK

IMPORTANT

The Manufacturing Number of the cooker should be quoted when ordering replacement fire bricks. This number will be found on a brass plate inside the roasting oven.

THE NO.3
'RAYBURN'

REGD. TRADE MARK

INSULATED COOKER AND WATER HEATER

will do all your cooking
and give all the Hot Water you need
on 1½ cwts of fuel per week

Another splendid fuel-economy appliance by

ALLIED IRONFOUNDERS LIMITED



28 BROOK STREET, LONDON, W.1

Thousands of housewives all over Britain find it so much easier to be houseproud since they installed a Rayburn.

For one thing, the Rayburn *looks* so well. It is compact, of modern design and, above all, wonderfully easy to clean. It takes so much of the drudgery out of housework.

It does all the cooking for a family of up to six people. Never in your life have you tasted meals as delicious as those that come from the Rayburn.

And, oh, the joy of having piping-hot water all day long. Hot water for washing-up and other domestic purposes, for up to three baths a day and plenty for a big Monday wash, besides.

Then, the way your fuel bills fall. The No. 3 Rayburn is far more efficient than any old-fashioned cooker. It makes the best use of each lump of fuel and puts it to work cooking, water-heating or warming the kitchen. So it's really no wonder that the Rayburn does so much more on less fuel.

But this is merely an outline of the Rayburn's amazing performance.

FOR THE FULL STORY—just read on

Uses any type of fuel The No. 3 Rayburn is not restricted to one type of fuel and works equally well on coke, anthracite, coal, or manufactured fuels, on any of which it will remain alight all night. But it readily burns wood or even peat. The comprehensive working instructions supplied with every cooker tell you how to get the best and most economical results from whatever fuel you use.

Two ovens The No. 3 Rayburn has two ovens. The roasting oven fitted with a thermometer is big enough to take a large turkey. This oven has a patented method of convection heating which gives a steady and even heat.* This means juicier, more tender meat dishes, lighter cakes and better pastry than you've ever made before. The warming oven below heats plates or keeps food unspoiled should guests or members of the family be delayed.

** There is a full explanation of this outstanding feature on the back cover.*

Big, fast hotplate The hotplate is fitted with deep fins to collect and concentrate the heat of the fire. Put a kettle on this hotplate and it boils in a few minutes, while, at the other end of the hob, soups and stews simmer slowly and safely.

Automatic hot water The No. 3 Rayburn produces hot water automatically all the time it is alight. This does not interfere with its cooking performance.

Insulating cover keeps the heat in The insulating cover is designed to keep heat in the cooker and thus save fuel when the cooker is not in use.

The insulating cover also helps to prevent your kitchen from getting too hot in summer. But when you come down even on the darkest, coldest mornings, the kitchen is always warmly welcoming. You riddle your Rayburn and soon the fire is burning up brightly and the kettle boiling briskly on the hob.

Easy to control The No. 3 Rayburn has two controls only, a flue damper, and a spin-wheel on the ashpit door. After a little practice, you will find yourself able to control cooking temperatures at will with great accuracy.

Easy to fuel The big fire door is in the front of the No. 3 Rayburn. This makes re-fuelling both easy and clean. For it means that smoke and dust do not rise into your kitchen. Fuelling the Rayburn is an infrequent operation, for the firebox holds enough fuel for up to ten hours burning at the minimum rate of burning.

Riddled from the outside The No. 3 Rayburn needs riddling only three or four times a day, depending on how much cooking you do, and the job takes less than a minute. What's more, thanks to the special built-in riddling device, you don't even have to open the fire or ashpit doors.

All you do is insert the special tool provided into the slot of the riddling handle (between the simmering oven and ashpit doors) and move it backwards and forwards a few times. The circular grate rotates and deposits all the ash in the ashpan. There are no awkward corners to clog up. Since the fire and ashpit doors are tightly closed, dust and ash cannot possibly fly out into your kitchen. What could be simpler? What could be cleaner?

Easy to clean The No. 3 Rayburn's ashpan requires emptying only once a day. And, of course, the Rayburn's hard, vitreous enamel finish needs only a wipe over with a damp cloth to bring it up bright as a new pin. Moreover, the patented method of heating the oven does away with oven flues. All you ever need to do with the Rayburn is occasionally to push the soot from the top of the oven into the fire. You need not even let the fire out.

Low installation costs The No. 3 Rayburn is free-standing and is delivered as a self-contained unit. This saves any expensive brickwork or building-in costs. The flue outlet is adaptable to either horizontal or vertical connection. The boiler connections, which are at the side, are available either left or right handed.

Extras Hinged insulating cover for cooker with side connections. Loose insulating cover. Plate rack and splashplate. Plate rack only. Hand rail. Bower barbed wrought welded boiler. Copper boiler.

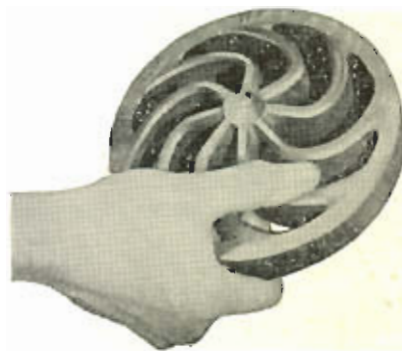

This is the new Rayburn circular grate. It gives quick, easy and thorough riddling. Ash cannot build up against the side of the fire box.

Facts and figures ABOUT THE NO. 3 RAYBURN



OVERALL DIMENSIONS. Width 33 in. Height to top plate 32 in. Depth 18½ in. Height to top of splashplate 52½ in. If the cooker is to be installed in a recess, an additional 6 in. at least for plates should be allowed. Flue outlet takes 5 in. smoke pipe and is adaptable to either horizontal or vertical outlet.

OVENS right or left hand. Roasting oven 14 in. wide × 12 in. high × 16 in. deep. Warming oven 14 in. wide × 8 in. high × 16 in. deep.

HOTPLATE 21½ in. wide × 7½ in. deep. Area 1.16 sq. ft.

BOILER. The boiler can be plain wrought welded, bower barbed wrought welded or copper. The boiler connections are 1 in. B.S.P. and at the side only. Recommended size of the cylinder 30 gallons (direct or indirect). The Rayburn will *not* serve a radiator or a secondary circulation. The Rayburn can also be supplied without boiler.

When ordering please indicate whether you require the oven on the left or right hand, whether the flue outlet will be on the top or at the back, and whether a plain wrought welded, bower barbed, or copper boiler is required.

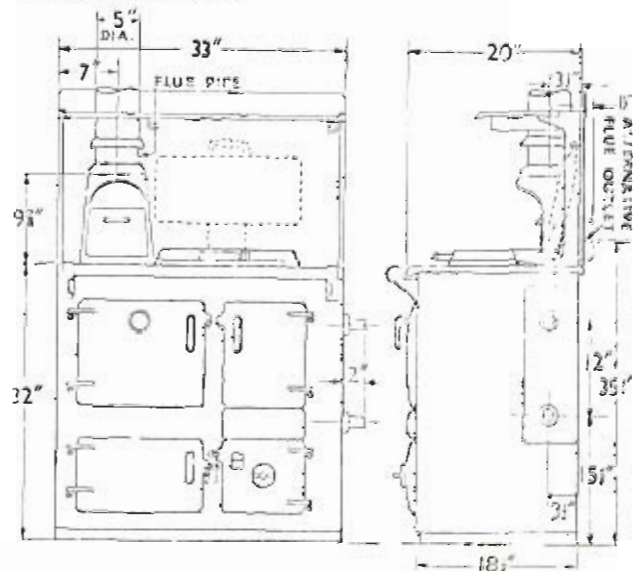

This patented method gives steady oven heat . . .

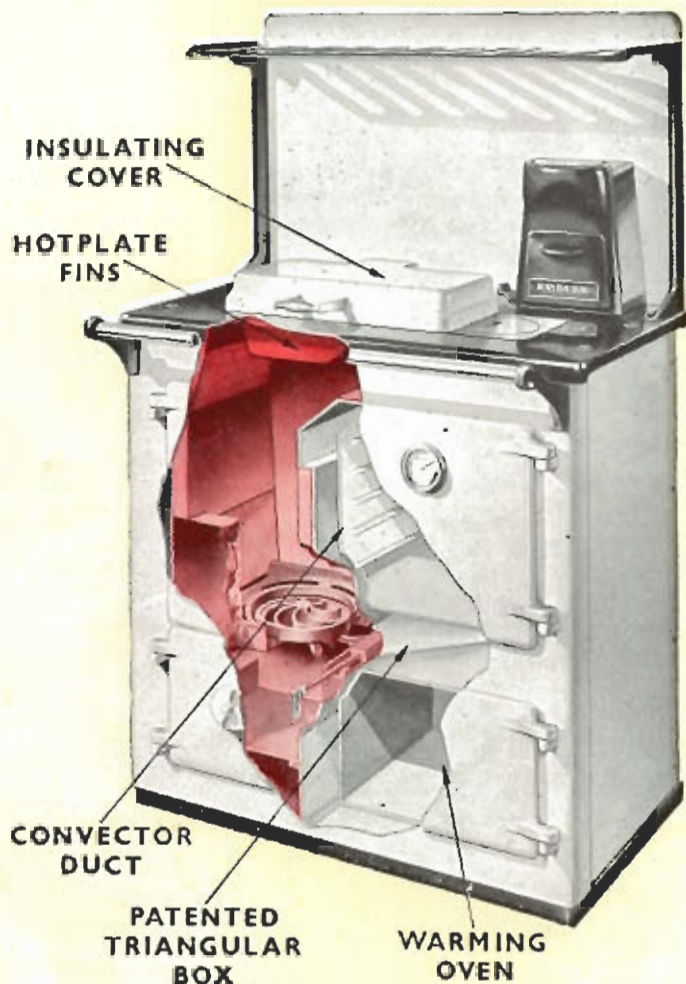

The ovens of most cookers are heated by hot gases passing completely around the oven as they go from the fire to the flue. This results in dirty oven flues which may be difficult to clean. Another disadvantage is that oven heat may be unevenly distributed.

In the No. 3 Rayburn, the oven is heated by a different method which ensures a *steady* and *even* heat. The top is heated by flue gases passing over it and the *side next to the firebox* is heated from the firebox. The *bottom* is heated by radiated and reflected heat through the Rayburn patented triangular box shown in the illustration. The *far side and back, as well as the door side*, are heated by conducted heat and by currents of hot air through the patented convector duct inside the oven—see the illustration.

This new and original heating system is largely responsible for the Rayburn's amazing performance. Both in cooking and the supply of hot water, the Rayburn more than meets the requirements suggested by official committees and complies with British Standard 1252:1945. It is, of course, an 'Approved Appliance'.

PATENT NOS. 408541, 505458

THE No. 3 RAYBURN

REGD. TRADE MARK

Insulated cooker and water heater

Manufactured by
The Coalbrookdale Company Ltd., Wellington, Shropshire.
Planet Foundry Co. Ltd., Audenshaw, Manchester.
The Falkirk Iron Co. Ltd., Falkirk, Stirling.

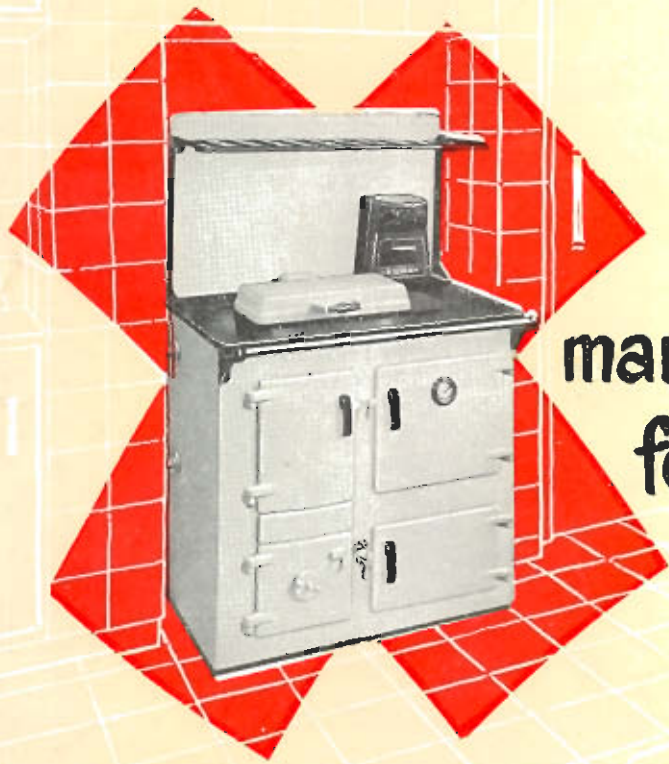

marks the spot
for the No 3 Rayburn

THE No. 3 RAYBURN COOKER*Trade Mark***PRICES AND TRADE DISCOUNTS**

(For specification see List No. 100/56)

The MAINTAINED PRICES to the General Public, strictly nett, are:—

	£ s. d.
Standard Model complete with wrot welded boiler, plate-rack, splashplate and handrail	50 0 0

No. 3 Rayburn can be supplied with the following special fittings at the extras indicated:

	£ s. d.		£ s. d.
Split Sealing Collar for Flue Pipes:		Wrot Welded Boiler Bower Barffed	15 8
Fine Cast	5 8	Deduction: if supplied with brick in place of	
Black Vitreous Enamel	9 0	boiler	Less 1 10 0
Copper Boiler instead of Wrot Welded ...	6 13 8		

THESE PRICES ARE SUBJECT TO ALTERATION WITHOUT NOTICE AND ARE AT PRESENT SUBJECT TO A PLUSAGE OF **5%**
AND APPLY TO THE U.K. MAINLAND ONLY

TRADE DISCOUNTS TO MERCHANT STOCKISTS:

For Delivery to Warehouse: Any quantity, Less 25%

For Delivery Direct in lots of 1 to 3 to one address and in one consignment, Less 20%

For Delivery Direct in lots of 4 and over to one address and in one consignment, Less 25%

QUANTITY ALLOWANCE TO MERCHANT STOCKISTS:

For Delivery to Warehouse only in lots of 6 and over, Less 5%

ABOVE DISCOUNTS Less 5% Monthly Account**TRADE DISCOUNT TO BUILDERS, PLUMBERS AND HEATING ENGINEERS:**

For their OWN requirements, Less 7½%

LESS 2½% Cash Discount

No. 3 Rayburn manufactured by:

PLANET FOUNDRY CO. LTD., GUIDE BRIDGE, NEAR MANCHESTER**THE COALBROOKDALE CO. LTD., WELLINGTON, SHROPSHIRE**

(Proprietors: Allied Ironfounders Ltd.)



RAYBURN

REGISTERED TRADE MARK

COOKERS

U.K. Patent Nos.: 408541, 505458 and 666809

MODELS 1, (2) & 3

★

Installation Instructions and Dimensioned Drawings

★

Rayburn Cookers are delivered as self-contained units ready for installation. Instructions for the preparation of the site and for the assembly and connection of the boiler are given overleaf.

★

THE HOT WATER SYSTEM

With normal usage the Rayburn No. 1 has an output of approximately 90,000 B.Th.U. and the Rayburn Nos. 2 and 3 of approximately 100,000 B.Th.U. in 24 hours continuous burning. This is sufficient for 2 or 3 hot baths at intervals and normal household requirements provided the following conditions are fulfilled:

- 1 The capacity of the storage cylinder must not exceed 35 gallons. The recommended capacity is 30 gallons (direct or indirect).
- 2 The cylinder must be effectively lagged, and must be fixed vertically.
- 3 The cylinder should be as near as possible to the cooker. In no case must 1 in. flow and return pipes exceed 30 ft. each in length. 1½ in. pipes must not exceed 24 ft.
- 4 1 in. flow and return pipes exceeding 15 ft. each in length must be lagged. 1½ in. pipes exceeding 12 ft. must be lagged.
- 5 The draw-off pipe to the taps must be a 'dead-leg' connection from the expansion pipe.
- 6 A towel rail of not more than 6 sq. ft. heating surface may be heated provided the flow and return pipes are not more than 15 ft. each in length, and provided the cylinder and the pipes to the cylinder and towel rail are lagged. A radiator is not permitted.

To obtain the above-mentioned outputs the fire must be left in overnight.

IMPORTANT

The above instructions must be strictly observed. If they are disregarded e.g. an unlagged or oversize cylinder, consumption of fuel will be excessive, and the cooker may be damaged by over-firing.

FLUE LAYOUTS

● In Figure 1 the Rayburn is installed in an existing recess. There must be a clearance of not less than 6" between the top of the flue pipe and any overhanging brickwork.

● If the cavity above the register plate is more than 3 ft. high the flue pipe must be carried up to the throat of the chimney (Figure 2). In this type of installation it may be necessary to seal the flue pipe into the throat of the chimney, and provide a soot door for chimney sweeping.

● In Figure 3 the Rayburn is connected direct to a brick flue.

● In Figure 4 the Rayburn is connected to an existing brick flue with a length of flue pipe. Square bends and horizontal runs must not be used. There must be a cleaning door at every bend.

NOTE

Whatever method of installation is employed air must not be allowed to enter the chimney except through the cooker. *All joints must be airtight.* Provision must always be made for sweeping the chimney.

IMPORTANT

Flues consisting wholly of this type are not recommended.

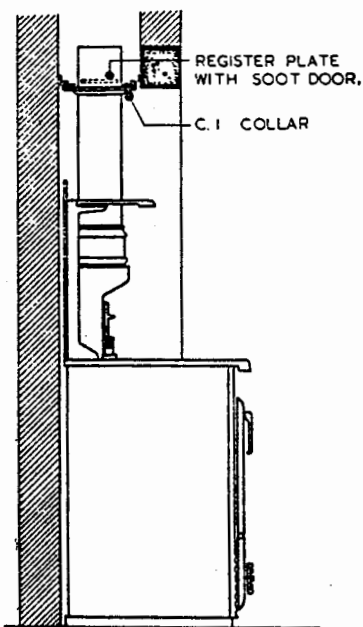

FIG. 1

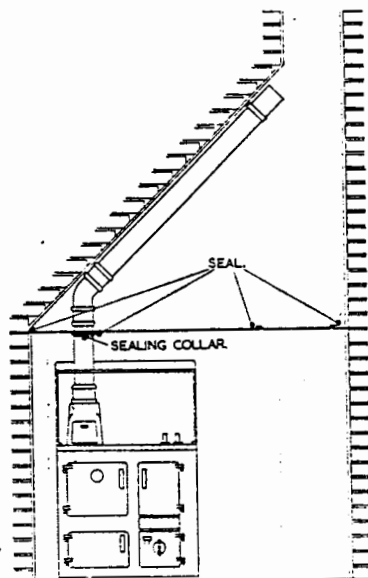

FIG. 2

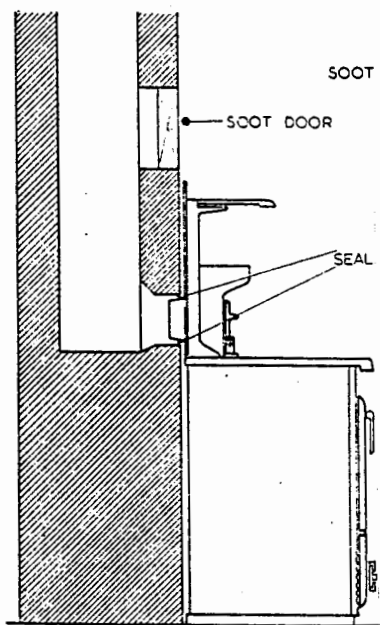

FIG. 3

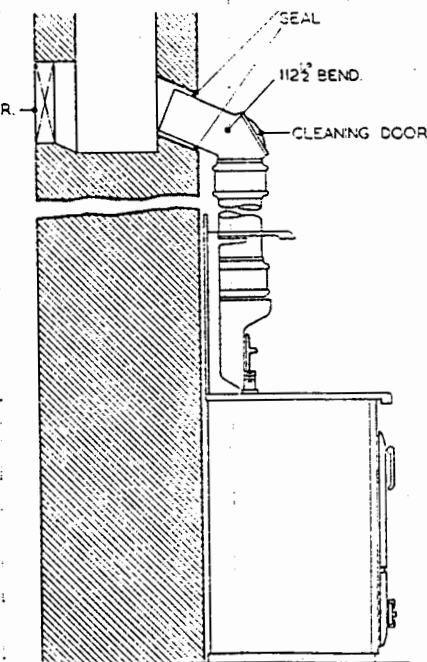

FIG. 4

Products of Allied Ironfounders Ltd.

Manufactured by:

The Falkirk Iron Co. Ltd.
Falkirk . . . Stirlingshire

No. 1 Rayburn

Dobbie Forbes & Co. Ltd.
Larbert . . . Stirlingshire

Nos. 2 & 3 Rayburn

Planet Foundry Co. Ltd.
Guide Bridge, Nr. Manchester

The Coalbrookdale Co. Ltd.
Wellington . . . Shropshire

The Falkirk Iron Co. Ltd.
Falkirk . . . Stirlingshire



PREPARATION OF THE SITE

When a properly constructed hearth is not available we recommend that the Rayburn Cooker be placed on a slab of foamed slag concrete not less than 4 in. thick, or on a slab of other material providing equal insulation.

The position of the flue outlet is indicated in the dimensioned drawings. Alternative flue layouts are illustrated on the back page. The flue chamber can be adapted to give either a horizontal or vertical outlet, the horizontal type being used when there is a brick flue immediately behind the cooker, the vertical type when the cooker is connected to the main flue by means of flue pipe.

THE BOILER

Instructions for connecting the boiler to the hot water cylinder:

(a) **Top Connections.** Unscrew the two small sections of the hob above boiler and remove sufficient insulating material to allow a free passage for the boiler. Tilt boiler backwards and lift it out.

Joint the flow and return connections to the boiler. The return connection is the one with the dip pipe.

Before replacing boiler, run fire cement down side flanges. Place the boiler tight against side flanges and fill the cavity at back and on top completely with insulating material.

The boiler is now ready for connection to the hot water cylinder. It is advisable to fit a draw-off cock on the return pipe immediately above the cooker.

Having connected up, fill the spaces above and below the boiler, and between the boiler and the fire bricks, with the fire cement provided. Make good also any joints between fire bricks which may have opened up in transit.

(b) **Side Connections.** Unscrew the sheet metal cover plate on the side of the cooker and remove the insulating material from behind it. Joint the flow and return connections to the boiler, replace the insulating material and screw on the cover plate.

The boiler is now ready for connection to the hot water cylinder. Make sure that there are no dips in the flow pipe between boiler and cylinder. It is advisable to fit a draw-off cock on the return pipe close to the cooker.

Having connected up, fill the spaces above and below the boiler, and between the boiler and the fire bricks, with the fire cement provided. Make good also any joints between fire bricks which may have opened up in transit.

THE HOT PLATE

Lift off the surface ground hot plate and check the joints between the oven flue guides and the underside of the hob. Any joints which have opened up should be made good with the fire cement provided. Replace hot plate making sure that it is seating properly on the asbestos rope. It should be approximately 1/16 in. proud of the enamelled hob.

TESTING

When lighting the fire for the first time, allow the cooker to heat up gradually.

The four large screws in the hob are unscrewed a full turn at Works to allow for expansion. They should on no account be tightened.

RAYBURN Nos. 2 & 3

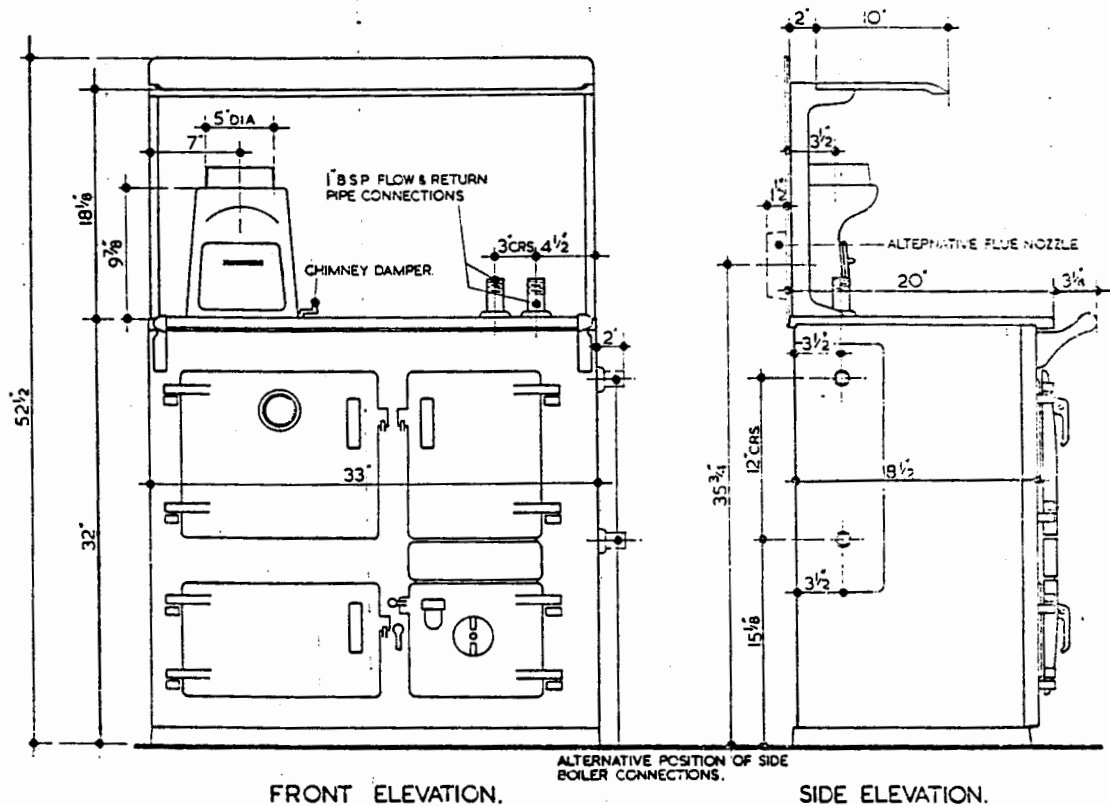

FRONT ELEVATION.

SIDE ELEVATION.

IMPORTANT NOTE. The hinged insulating cover cannot be fitted to the No. 3 Rayburn Cooker with boiler connections on TOP.

No. 3 RAYBURN COOKER

REG'D TRADE MARK

Working Instructions

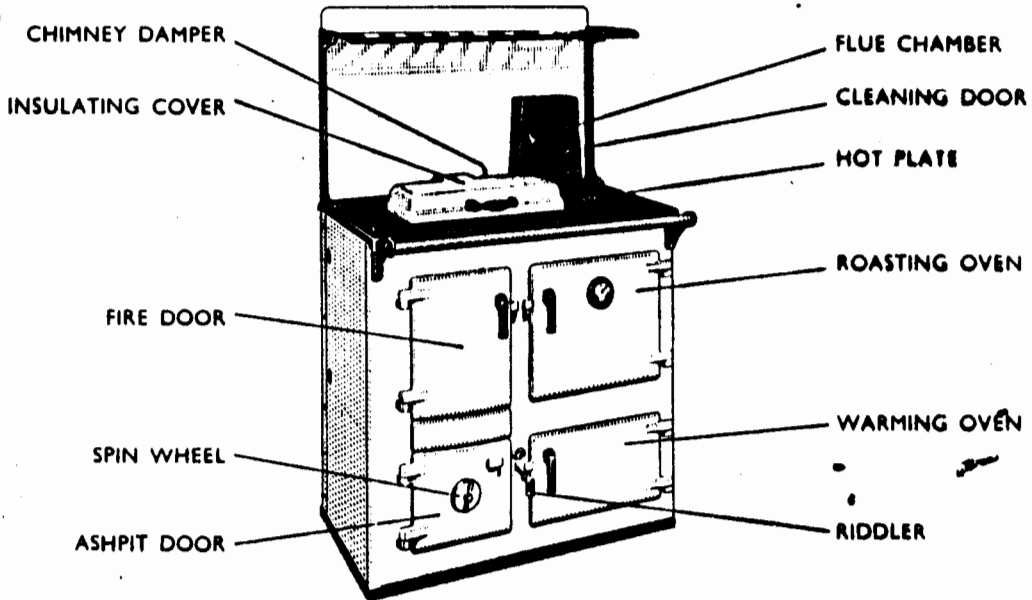

No. 3 RAYBURN Cooker



REG'D TRADE MARK

A product of

ALLIED IRONFOUNDERS LIMITED

SUNBURY · ON · THAMES, MIDDLESEX

FUEL & FUELLING

The recommended fuels are Coke 1 inch to 2 inches (No. 2 Broken Gas Coke), Sunbrite Doubles, Anthracite 2 inches to 3 inches (French Nuts), Dry Steam Coal 2 inches to 2½ inches (Large Nuts), Household Coal 1 inch to 3 inches, and manufactured fuels such as "Coalite," "Rexco" and "Phurnacite".

IT IS MOST IMPORTANT THAT THE FUEL SHOULD BE ADEQUATE IN SIZE. FUEL SMALLER THAN 1 INCH DOES NOT GIVE SATISFACTORY RESULTS.

Before fuelling, open the chimney damper to its full extent. Fill the firebox to the level shown in Fig. 1. It is not necessary to keep the fuel constantly at this level, but if the fire is allowed to burn very low there will be a time lag after refuelling before the heat reaches the oven, hotplate and boiler.

Do not fill the firebox above the level of the bottom of the fire door opening. Fig. 1. When burning coal or anthracite, time should be allowed for a fresh charge to ignite before the damper is closed.

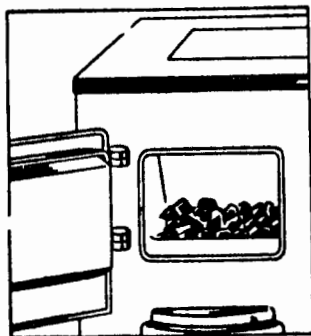

Fig 1

LIGHTING THE FIRE

Open the chimney damper, fire door and ashpit door. Kindle with paper and sticks in the ordinary way. Leave the doors open until the fire is well alight. Then close both doors, AND KEEP THEM CLOSED. Push chimney damper back to the position which has been found from experience to give the best results.

Note: After riddling to clear the ash, the kindling may be laid on top of any dead fuel lying on the grate.

If one is used a gas poker may be employed instead of paper and sticks. The gas poker can be inserted through the small cut-out immediately above the round grate.

RIDDLING

Open the chimney damper, and shake the bottom grate by a back and forth motion of the riddler at the side of the ashpit door. The tool provided should be used. Keep fire door and ashpit door closed. Remove ash from ashpit at regular intervals. If ash is allowed to accumulate until it touches the underside of the bottom grate, the bottom grate will quickly burn out. Use the tool as an ashpan lifting handle. Re-set chimney damper after riddling.

CONTROL

The fire is controlled by using the spin wheel on the ashpit door to govern the air supply. The chimney damper in the flue chamber is for reducing the chimney draught, and the more the damper can be closed the easier the cooker is to control.

Do not try to obtain a quick increase in temperature by opening the chimney damper to its full extent. This results in most of the heat being wasted up the chimney.

AVOID EXCESSIVE FIRE TEMPERATURES—THEY ARE NOT NECESSARY AND MAY DO SERIOUS HARM TO THE COOKER. THE FIRST SIGN THAT THE COOKER IS BEING OVERHEATED IS THE FORMATION OF CLINKER (MELTED ASH), AND CLINKER WILL DAMAGE THE FIRE BRICKS. DAMAGED FIRE BRICKS SHOULD BE REPAIRED WITH FIRE CEMENT OR IF NECESSARY REPLACED AS SOON AS POSSIBLE.

KEEP THE ASHPIT DOOR SECURELY CLOSED WITH CATCH PROVIDED.

For control of oven and hotplate temperatures see appropriate headings.

THE ROASTING OVEN

The correct adjustment of the spin wheel and chimney damper to obtain the oven temperature required varies with the chimney draught, and can be found only by experiment. The following is a suggested method only, and may need modification to suit local conditions.

Suppose an oven temperature for roasting is desired, and that the cooker is idling.

Thoroughly de-ash the fire as described in the "Riddling" paragraph. Add fuel to the level shown in Fig. 1. Set the chimney damper at half-way and open the spin wheel five complete turns. As soon as the fire has become nicely red all through, close the chimney damper. **DO NOT ALLOW THE FIRE TO BECOME WHITE HOT.**

The temperature of the oven should now rise steadily. When it reaches a point about 50° below that required, close the spin wheel to two turns open. Thereafter control the temperature of the oven by adjusting the spin wheel.

NOTE.—This method should prove successful in almost all cases, but if closing the chimney damper causes the fire to smoke, it should be opened gradually till the smoking stops.

To REDUCE top heat in the oven, place the sheet metal shelf on the top pair of runners.

The oven may be cleaned with a stiff wire brush when it is very hot.

OVEN TEMPERATURES:- Hot 400°—500° Moderate 300°—400° Slow 200°—300°

THE HOTPLATE

THE BEST RESULTS CAN ONLY BE OBTAINED BY USING FLAT-BOTTOMED UTENSILS. The hottest part of the hotplate is immediately above the fire; the other end is for simmering. The plug in front of the flue chamber is for flue cleaning and should not be removed for cooking.

Keep the hotplate clean with a wire brush.

HOT WATER SERVICE

The supply of hot water is automatic and special manipulation of the spin wheel and chimney damper is not necessary.

With a normal day's cooking, two or three baths and hot water sufficient for normal household requirements can be obtained. To provide this quantity of hot water the cooker should be kept in overnight and the hot water system MUST conform with the installation instructions. **IN PARTICULAR, THE CYLINDER MUST BE LAGGED.**

OVERNIGHT BURNING

The cooker is designed for continuous burning and the best results will only be obtained if it is allowed to burn overnight. It is no more expensive in fuel.

Last thing at night open the chimney damper, riddle the fire, empty the ashpan and fill up with fuel to the level shown in Figure 1. Do not overload. See that the ashpit door is securely closed. Close the spin wheel and reopen it a quarter of a turn.

The best position for the chimney damper can be found only by experiment, but for a start try closing it to a quarter of its length.

In the morning open the spin wheel and damper and riddle the fire. When it is burning brightly, close damper. If the hotplate is required immediately, do not refuel before use.

GRATE REMOVAL & REPLACEMENT

The bottom grate can be lifted out through the fire door. For replacement, make sure that the firebox is clear and lower the grate vertically by hand through the fire door. It is essential that the two projections on the rim of the grate are underneath, and engage the pin which forms the end of the riddling bar. See Fig. 2.

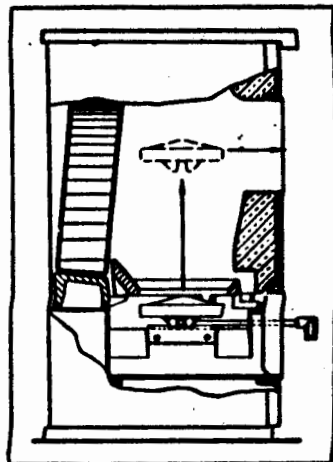

Fig 2

FLUE CLEANING

When burning coke or anthracite the flue should be cleaned once a month. Smoky coal may call for weekly cleaning. The procedure is illustrated in Figures 3, 4 and 5.

Allow the fire to burn out. Open the chimney damper and remove the cleaning door from the flue chamber. Brush the soot from the flue pipe, letting it fall on to the top of the oven. Remove the plug from the hotplate, rake the soot forward, and push it into the firebox.

Riddle the bottom grate thoroughly, clear the ashpit and relight the fire.



Fig 3

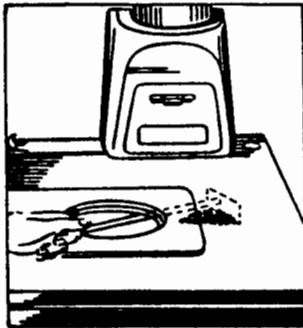

Fig 4

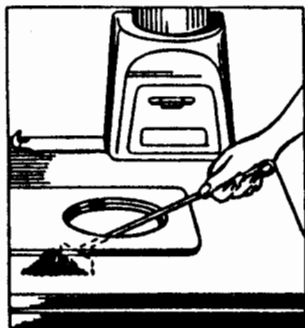

Fig 5

THE WARMING OVEN

This oven is primarily intended for heating plates and keeping food warm.

NOTE. Take care when closing the oven and fire doors to lift them on to the catch. The doors should not be slammed shut.

REMOVAL OF BOILER FOR CLEANING

(Instructions for Heating Engineers)

Turn off the water from the main and drain the system. Disconnect flow and return pipes, and unscrew side connections from the boiler. Top connections need not be unscrewed before lifting out the boiler.

Remove the section of hob above boiler and take out the insulating material. Tilt boiler backwards and lift out. After replacing boiler, repack the insulating material above and behind the boiler. Make good with fire cement the joints between boiler and fire bricks.

FIREBRICK REPLACEMENT

The firebricks fitted to "Rayburn" Cookers are of first quality manufacture, and providing the cooker has been installed and used correctly will have a reasonable life. They are, however, expendable items and in time will require renewal.

The renewal of firebricks is not a major operation and can be carried out by the average handyman. Replacement either in sets or singly can be obtained from your "Rayburn" distributor who can also supply a fixing chart on request. Always quote the manufacturing number.

The Manufacturing number, which will be found on a brass plate inside the Roasting Oven, should be quoted if any question arises in connection with the Rayburn Cooker