



# Servicing Instructions

Made by **AGA**

## Heatranger 480CD

For use in GB and IE

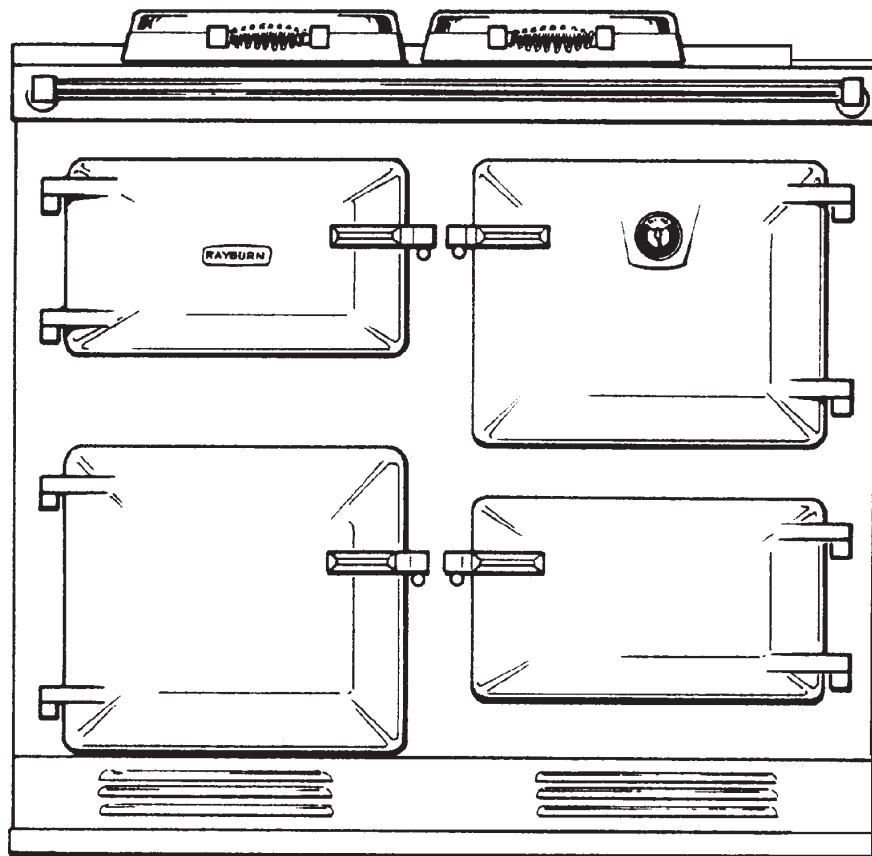

DESN 514712

**PLEASE READ THESE INSTRUCTIONS BEFORE SERVICING THIS APPLIANCE**

<b>SECTION</b>	<b>CONTENTS</b>	<b>PAGE</b>
	CONSUMER PROTECTION	3
	HEALTH & SAFETY	3
<b>SERVICING</b>	ANNUAL SERVICING	4
	SERVICE SCHEDULE	4
	PRE-SERVICE CHECK	5
	COMBUSTION AIR	5
	HOTPLATE CLEANING	5
	BURNER CHAMBER/SERVICING	5
<b>COOKER BURNER SERVICING</b>	PREPARATION	6
	BURNER ACCESS	6
	PARTS TO BE REMOVED TO WITHDRAW COOKER BURNER	6
<b>BOILER SERVICING</b>	BOILER SERVICE	7
<b>REPLACEMENT OF PARTS (ELECTRICAL CONTROLS)</b>	REPLACEMENT OF IONISATION PROBE	8
	REPLACEMENT OF ELECTRODE	8
	CONTROL BOARD REPLACEMENT	9 - 10
<b>REPLACEMENT OF PARTS (COOKER)</b>	TO FIT NEW DISPLAY PANEL AND COOKER THERMISTOR	11
<b>REPLACEMENT OF PARTS (BOILER BURNER)</b>	REMOVAL AND REPLACEMENT OF BOILER FAN	13
	TO FIT NEW BURNER	14
	TO FIT NEW IGNITION, IONISATION PROBE AND OVERHEAT	14
	ELECTRODE REPLACEMENT	14
	OVERHEAT STAT REMOVAL	15
	REMOVAL OF HEAT EXCHANGER, ACCESS PANEL AND CLEANING	15
	EXAMINATION OF HEAT EXCHANGER TRAY	15
	REPLACEMENT FLOW/RETURN SENSOR AND WATER PRESSURE SWITCH	16
	FAULT DIAGNOSTICS	17 - 18

## Consumer Protection

As responsible manufacturers we take care to make sure that our products are designed and constructed to meet the required safety standards when properly installed and used.

### **IMPORTANT NOTICE: PLEASE READ THE ACCOMPANYING WARRANTY**

Any alteration that is not approved by Aga could invalidate the approval of the appliance, operation of the warranty and could affect your statutory rights.

### **Health & Safety**

This appliance may contain some of the materials that are indicated. It is the Users/Installers responsibility to ensure that the necessary personal protective clothing is worn when handling where applicable, the pertinent parts that contain any of the listed materials that could be interpreted as being injurious to health and safety.

### **Glues and Sealants**

Exercise caution - if these are still in liquid form use face mask and disposable gloves.

### **Glass Yarn, Mineral Wool, Insulation Pads, Ceramic Fibre**

Maybe harmful if inhaled. May be irritating to skin, eyes, nose and throat. When handling avoid contact with skin or eyes. Use disposable gloves, face-masks and eye protection. After handling wash hands and other exposed parts. When disposing of the product, reduce dust with water spray, ensure that parts are securely wrapped.

### **NOTE: SMOKE/SMELL EMITTED DURING INITIAL USAGE**

Some parts of the cooker have been coated with a light covering of protective oil. During initial operation of the cooker, this may cause smoke/smell to be emitted and is normal and not a fault with the appliance, it is therefore advisable to open doors and or windows to allow for ventilation. Lift the lids to prevent staining the linings.

## ANNUAL SERVICING

It is important for the current operation of the appliance that servicing be carried out annually by a professional or competent person in accordance with gas safety regulations.

With normal use, a boiler/cooker service should be carried out immediately after the end of the heating season. The householder should be advised to turn off both boiler and cooker control knobs, the night preceding the day of the service, so that the appliance will be cooled down by the following morning, in readiness for servicing.

Before commencing any service, isolate the electricity supply, then turn OFF the gas supply at the gas service cocks.

**WARNING: ISOLATE UNIT FROM ELECTRICITY SUPPLY AND TURN OFF GAS AT SERVICE COCKS BEFORE SERVICING. AFTER COMPLETING SERVICE ALWAYS CHECK FOR GAS SOUNDNESS AND CHECK THIS FUNCTION OF CONTROLS.**

## SERVICE SCHEDULE

1. Carry out a pre-service check noting any operational faults.
2. Clean the hotplate.
3. Clean the cooker burner.
4. Clean the boiler burner.
5. Clean the heat exchanger.
6. Clean and empty any debris from condensate trap.
7. Check that the flueway is unobstructed.
8. Replace all gaskets that have degraded or broken.

## Servicing

### PRE-SERVICE CHECK

Operate the appliance and system, noting any faults which may need to be corrected during service.

### COMBUSTION AIR

Check that CO<sub>2</sub> levels are within tolerance see Technical Specification Fig. 1 in the Installation Instructions.

If these levels cannot be obtained, check gas rate and adjust the throttle screw if required and allow readings to stabilise. See Fig. 6.

### HOTPLATE CLEANING

SEE FIG. 1

Lift out the hotplate using lifting tools provided. Brush the fins with a wire brush to remove any deposits.

### COOKER BURNER CHAMBER/SERVICING

SEE FIG. 2

#### BURNER CHAMBER

**IMPORTANT: DURING CLEANING CARE MUST BE TAKEN NOT TO DAMAGE THE CERAMIC FIBRE INSULATION INSIDE THE COMBUSTION CHAMBER.**

1. Lift insulation covers and remove hotplate using lifting hooks provided.
2. Clean the flueway by inserting the flexible brush through top plate aperture, directing it towards the flue outlet. Scrape the deposits towards the burner chamber.
3. Thoroughly clean burner chamber flueway.
4. Carefully vacuum any debris that has fallen down into the burner chamber.
5. Replace the hotplate ensuring the underside ribs lie over the oven, and that it seals to the top plate.

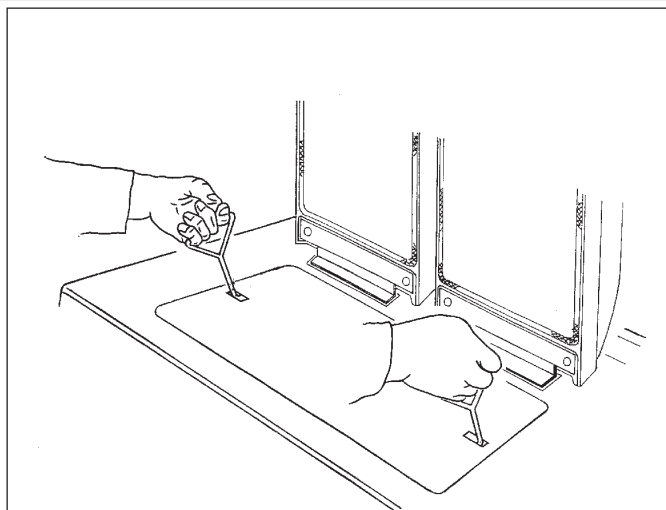

FIG. 1

DESN 510145 A

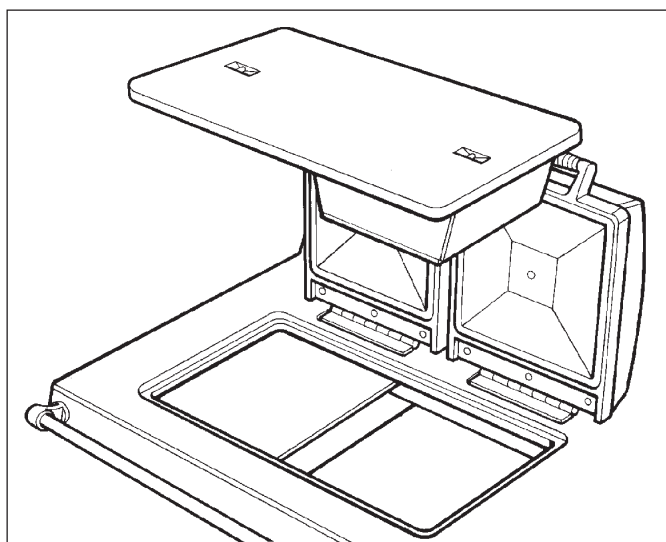

FIG. 2

DESN 514992J

## PREPARATION

**WARNING: BEFORE REMOVING SERVICE ACCESS COVERS OR THE BURNERS ENSURE THAT ALL ELECTRICAL SUPPLIES TO THE APPLIANCE HAVE BEEN ISOLATED.**

## BURNER ACCESS

SEE FIG. 3

1. Open up the bottom door access door. Remove door and put in a safe place.
2. Remove the 4 inner panel securing screws and remove panel.
3. Remove the 3 plinth securing screws and remove plinth.

## PARTS TO BE REMOVED TO WITHDRAW COOKER BURNER

1. Ensure cooker gas cock is closed.
2. Disconnect flexible gas inlet as shown, ensuring not to lose o-ring. (See Fig. 4).
3. All of the items in Fig. 5 need to be disconnected before the burner assembly can be removed.

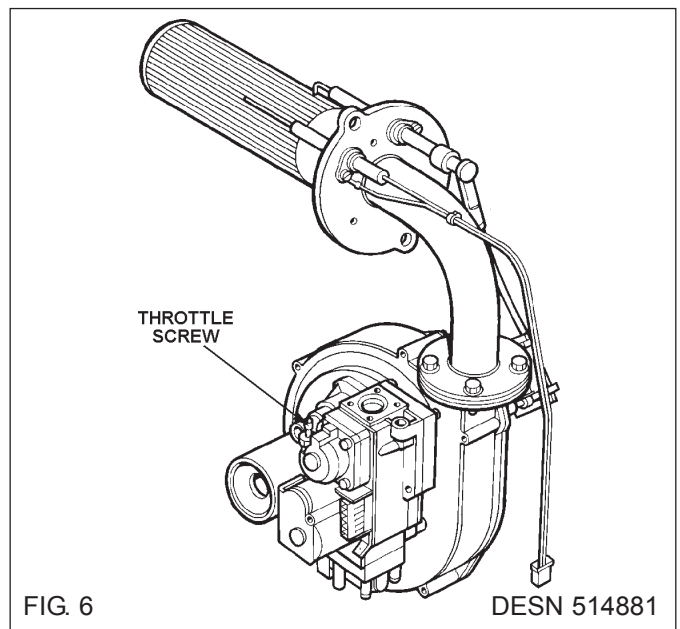
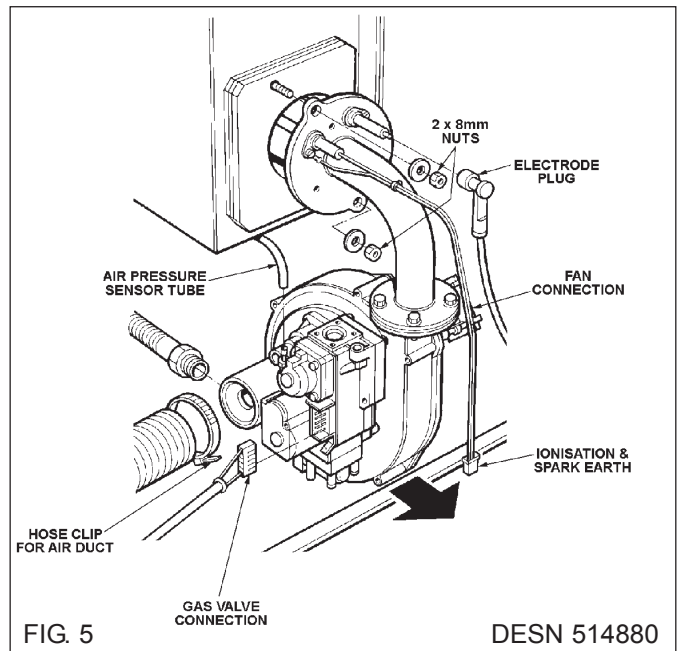
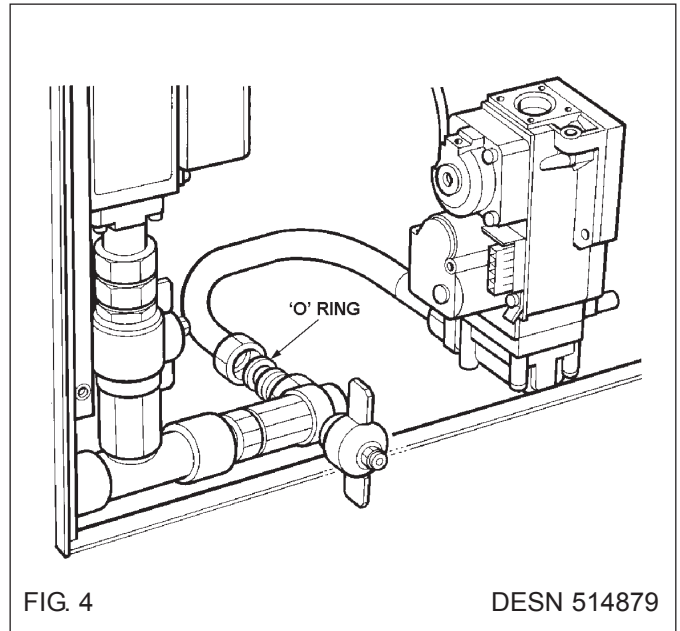
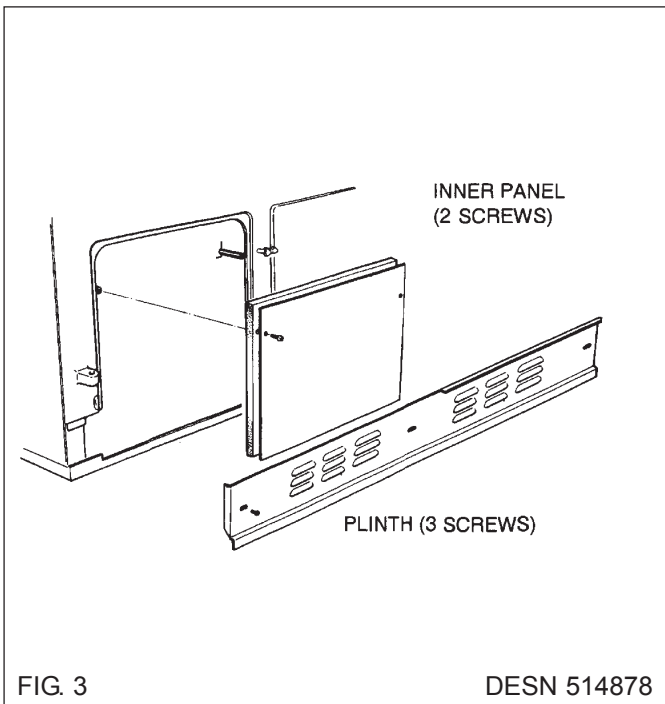

# Boiler Servicing

## BOILER SERVICE

### CONDENSATE TRAP SERVICE

Unscrew condensate trap base and check for excessive deposits. If levels are acceptable wash out any deposits and replace. (See Fig. 7)

### COMBUSTION ANALYSIS

Check that the CO<sub>2</sub>/CO levels are within tolerances shown in Fig. 1.

To check the levels at full rate, turn the boiler knob fully clockwise.

To check the levels at the low rate, turn the boiler knob to the first segment on the dial.

If these levels are within the tolerance, no further action is required with the boiler.

If levels are not within tolerance check for possible causes e.g. blocked flue, faulty fan etc. If no other fault can be detected, the gas valve needs to be adjusted manually.

To do this, turn the boiler knob fully clockwise to create the highest possible demand.

Check that CO<sub>2</sub>/CO levels are within stated levels (See Fig. 1). If the valve are found to be inconsistent with these, turn the gas valve regulator A (See Fig. 8) in the appropriate direction. Turning clockwise will decrease the CO<sub>2</sub>; turning anti-clockwise will increase the CO<sub>2</sub>. Please note that due to the sensitivity of the screw, only small adjustments will be necessary.

Once adjustment has been made, wait until CO<sub>2</sub> level stabilises and recheck the combustion. Repeat the above steps as necessary.

Check that CO<sub>2</sub> levels are within stated levels at minimum rate, turn knob to first segment on the display.

Using the method detailed above, run the boiler at its minimum output. Wait for the boiler to stabilise and perform the combustion analysis, check the results against those in the Technical Specification Fig. 1. in the Installation Instructions.

If the valves are found to be inconsistent with these, turn the gas valve regulator B (See Fig. 8) in the appropriate direction. Turning clockwise will increase the CO<sub>2</sub>; turning anti-clockwise will decrease the CO<sub>2</sub>. Please note that due to the sensitivity of the screw, only small adjustments will be necessary (1/8 of a turn).

**NOTE:** Unscrew cap and adjust accordingly.

Once adjustment has been made, wait until the CO<sub>2</sub> level stabilises and recheck the combustion. Repeat the above steps as necessary.

**After completion of calibration, recheck the CO<sub>2</sub> at maximum output. It is also advisable to check the gas capacity at the metre against the figures given in the technical specification in Fig. 1.**

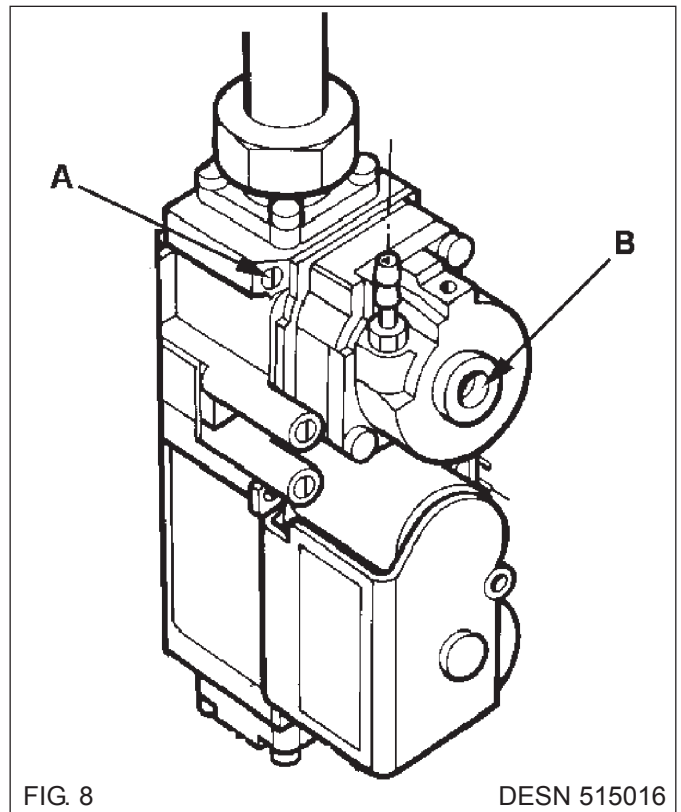
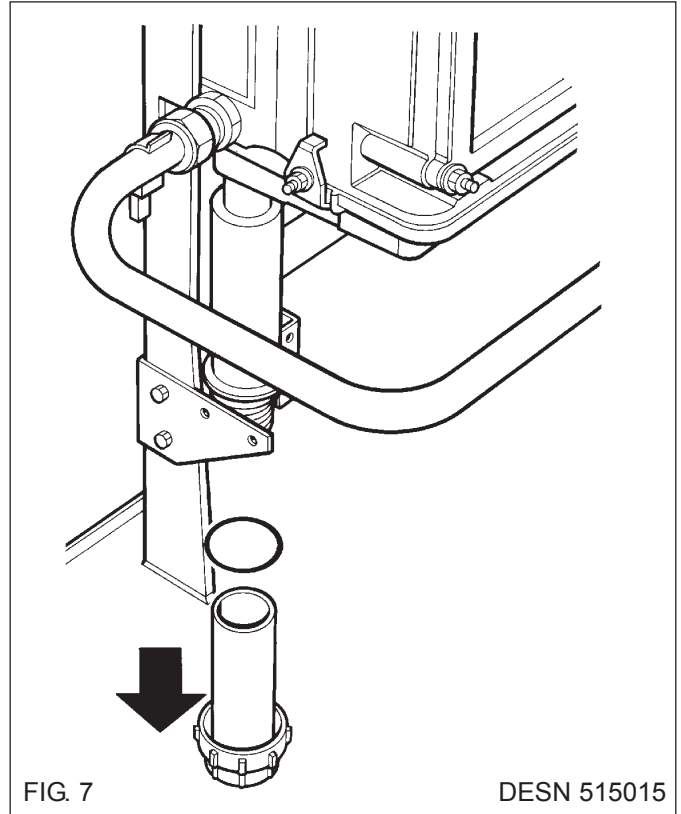

## Replacement of Parts (Electrical Controls)

### REPLACEMENT OF IONISATION PROBE

SEE FIG. 8

1. Turn off power to the appliance.
2. Unscrew the fixing screw and withdraw probe.
3. Replace probe, ensuring both the gasket and spark return are also fitted.

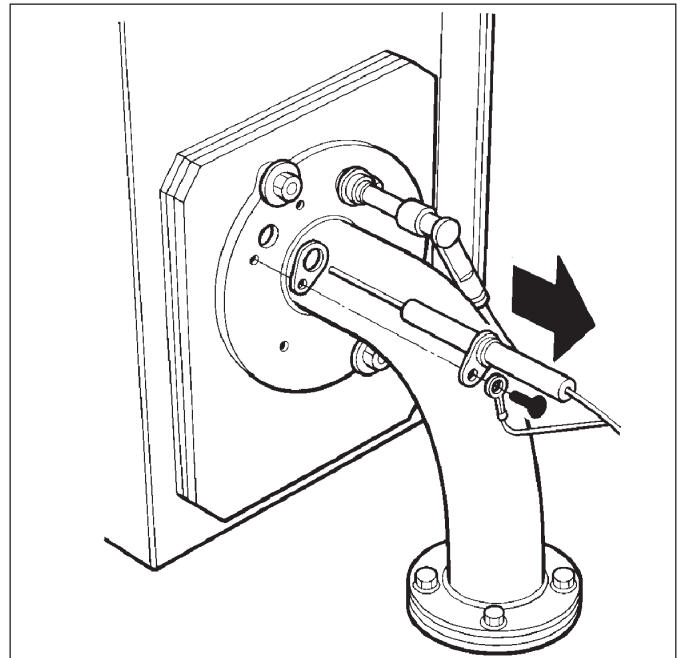

FIG. 8

DESN 514882

### REPLACEMENT OF ELECTRODE

SEE FIG. 9

1. Turn off power to the appliance.
2. Unscrew the fixing screw and withdraw probe.
3. Unclip the electrode plug, by simply pulling away
4. Replace electrode and gasket and screw in tightly.

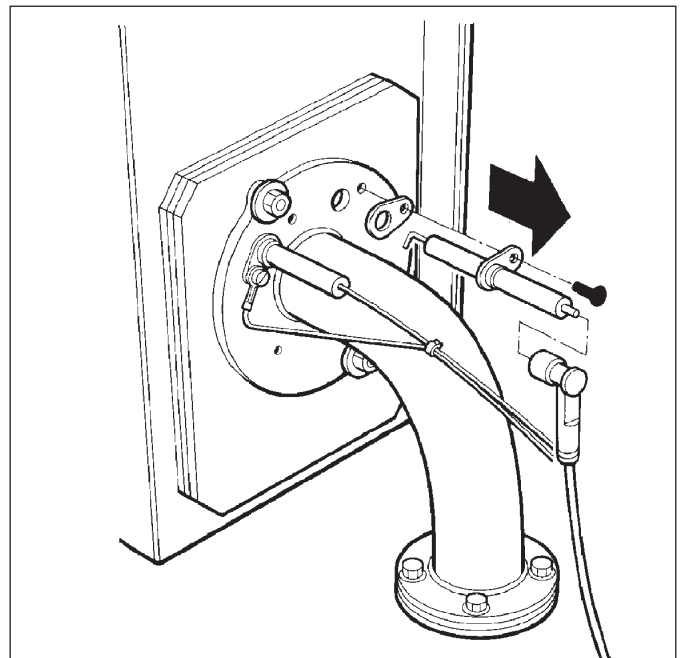

FIG. 9

DESN 514883

## Replacement of Parts (Electrical Controls)

### CONTROL BOARD REPLACEMENT

SEE FIGS. 10 & 11

1. Remove plinth.
2. Unscrew 2 bolts fixing the board to the base.
3. Move the terminal strip and bracket to allow removal of the main PCB.
4. The extra lengths on the wires should allow the PCB to be withdrawn to the front of the appliance.
5. All of the connections can then be disconnected.
6. To replace the PCB, unscrew the 4 bolts and then simply fit a new control board.

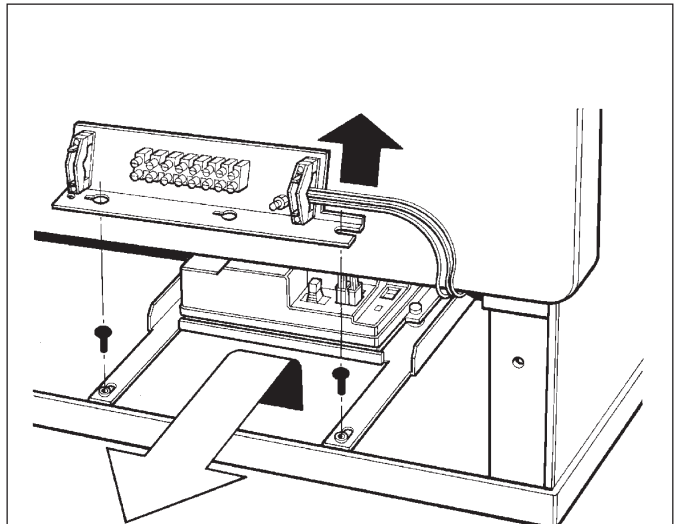

FIG. 10

DESN 514885

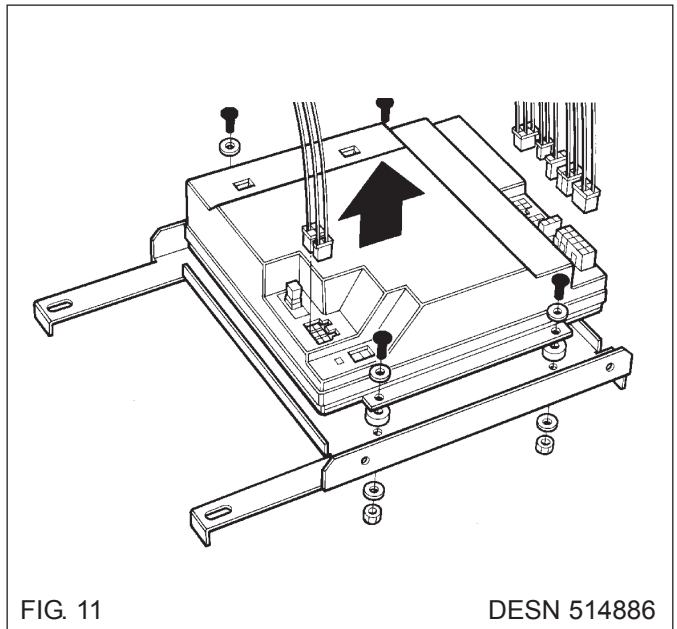

FIG. 11

DESN 514886

# Replacement of Parts (Electrical Controls)

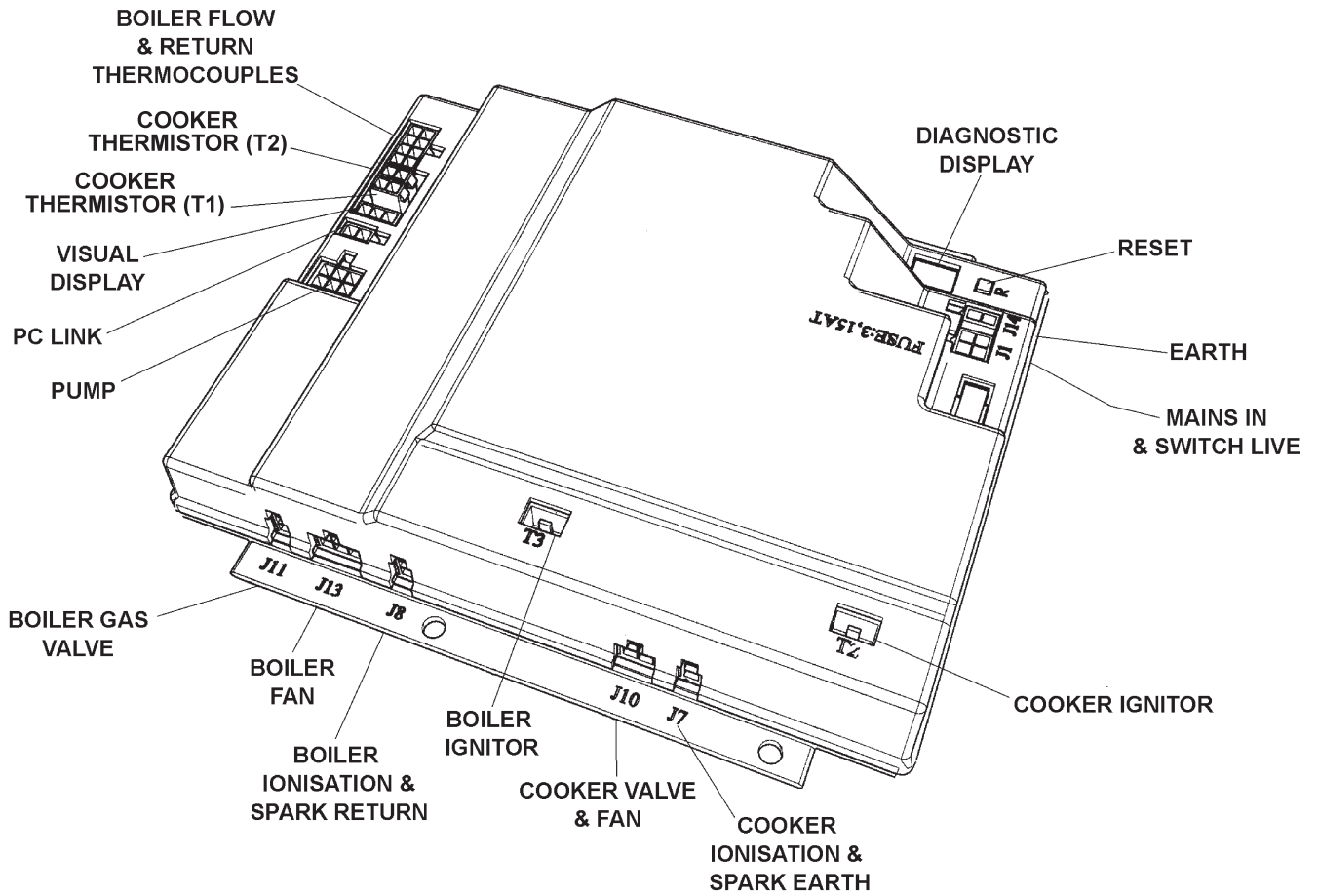

FIG. 12

## Replacement of Parts (Cooker)

### TO FIT NEW DISPLAY PANEL & COOKER THERMISTOR

SEE FIG. 13 & 14

1. Remove glass front facia by unscrewing buttons and removing 2 M5 screws.
2. Pull off control knobs and remove glass.
3. Undo 4 screws on the chassis and remove from front plate ensuring electrical connector is disconnected.
4. Disconnect required thermsistor from main board.
5. Remove thermistor from the tie wrap clamp.
6. Unscrew required thermocouple using a spanner. (See Fig. 14)
7. Replace with new thermocouple and re-connect.
8. Replace all parts in reverse order.

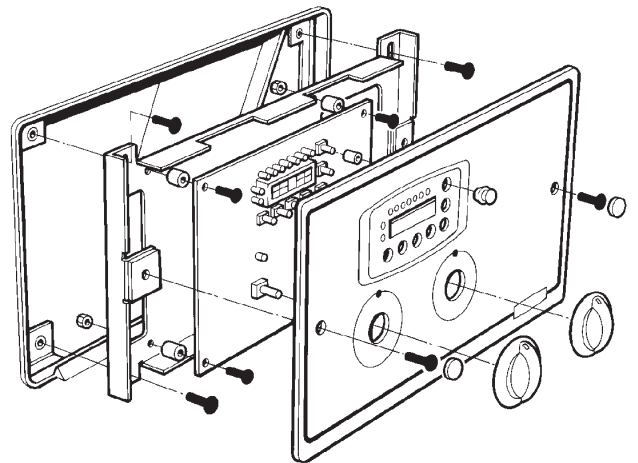

FIG. 13

DESN 514887

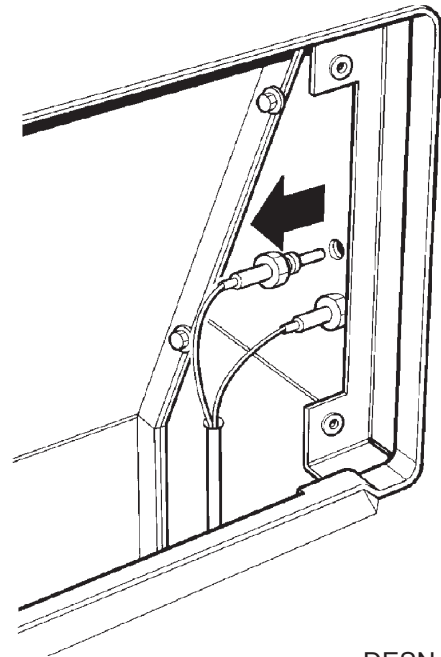

FIG. 14

DESN 514888

## Replacement of Parts (Boiler Burner)

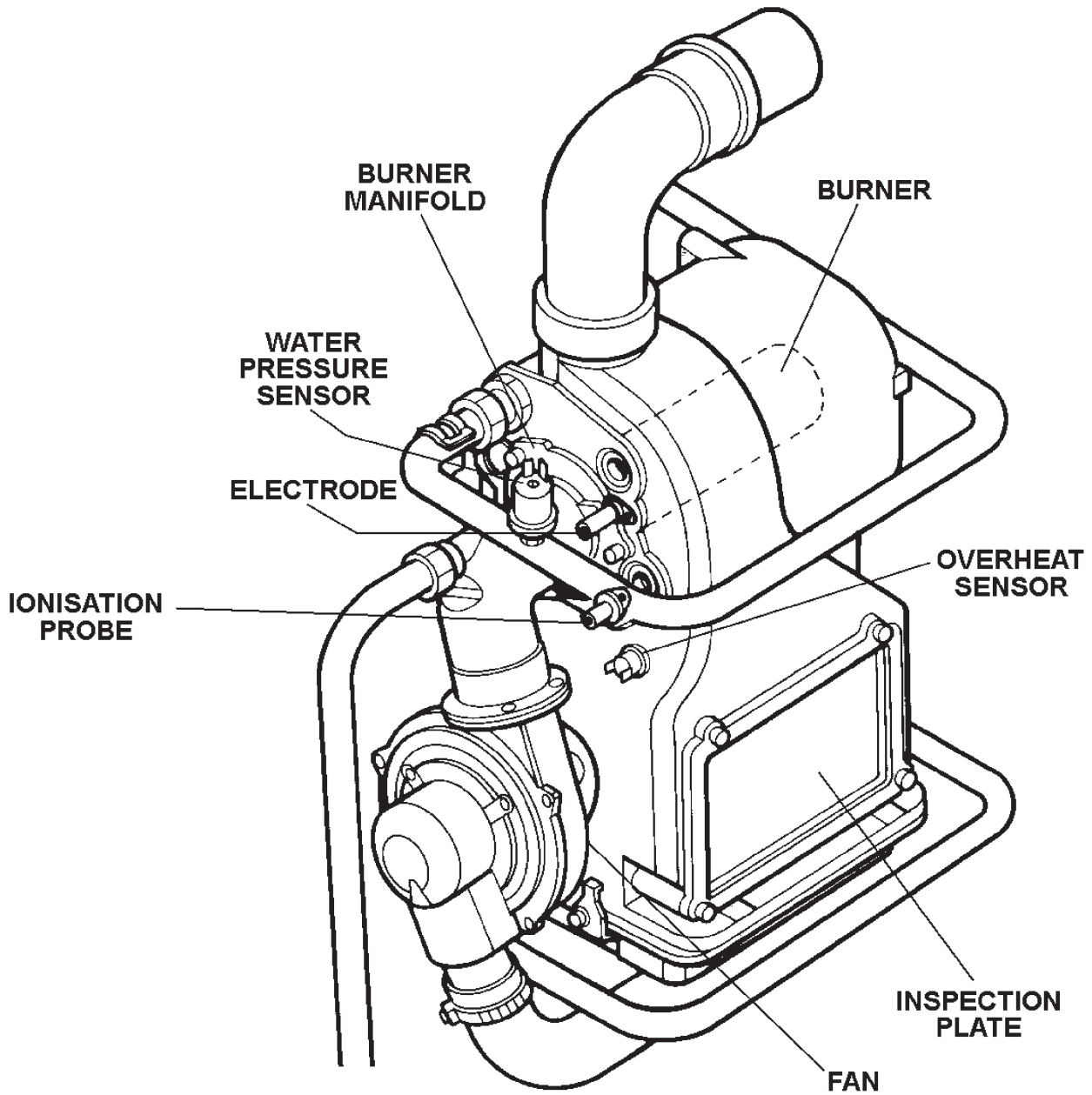

FIG. 15

## Replacement of Parts (Boiler Burner)

### REMOVAL AND REPLACEMENT OF BOILER FAN

1. Close boiler gas cock.
2. Unscrew boiler gas inlet. (See Fig. 17).
3. Remove 3 M6 nuts from boiler manifold. (See Fig. 17)
4. Unscrew boiler gas valve connections and remove gas train. (See Fig. 16).
5. Disconnect air inlet duct by unscrewing hose clip (See Fig. 18).
6. Disconnect electrical connection at the back of the fan. (See Fig. 18).
7. Remove air pressure tube from gas valve (See Fig. 16).
8. The manifold and fan can now be pulled out and removed through the lower service door entry.
9. To separate the fan from the manifold, unscrew the 2 x M5 cap head screws with an appropriate allen key. (See Fig. 18).
10. The fan and manifold can now be separated.
11. The air inlet manifold is removed by unscrewing the 3 x M4 screws. (See Fig. 19).

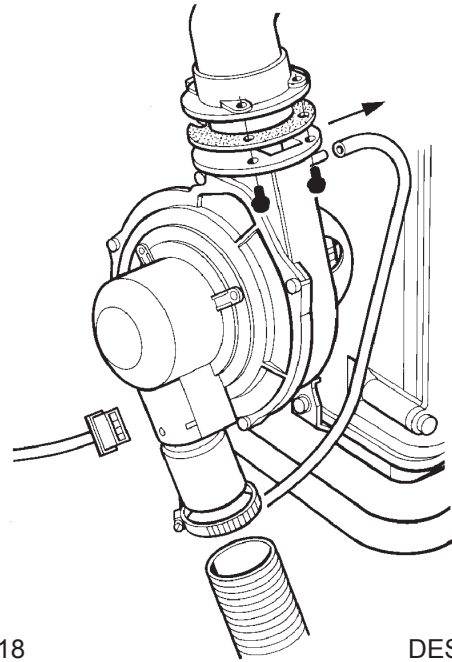

FIG. 18

DESN 514892

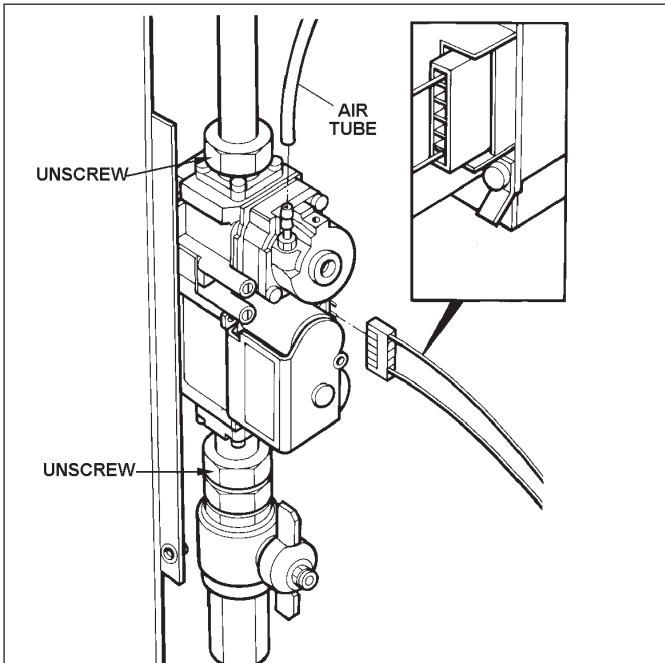

FIG. 16

DESN 514890

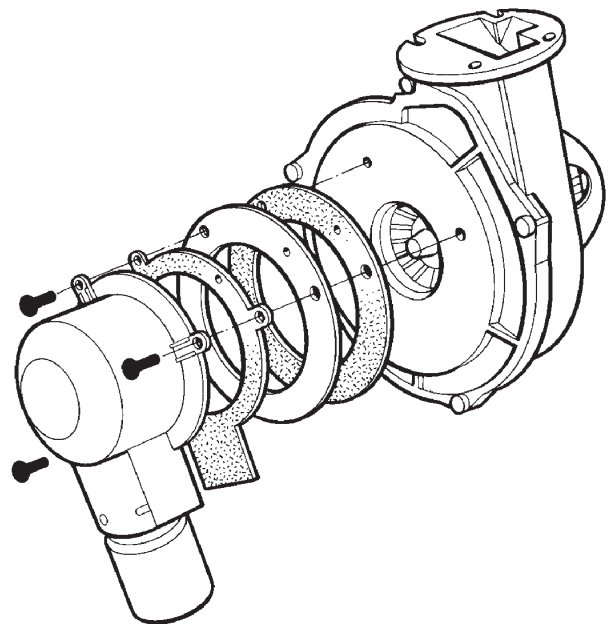

FIG. 19

DESN 514893

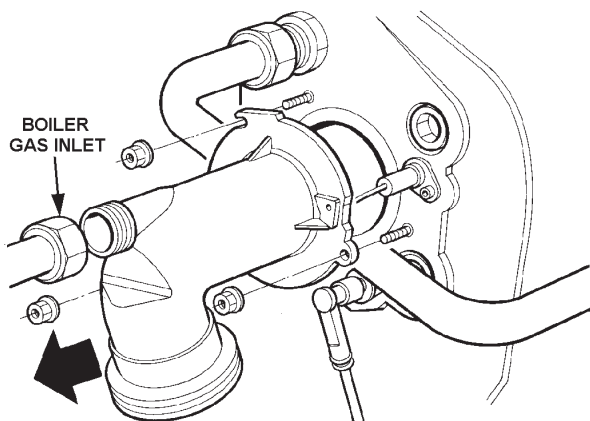

FIG. 17

DESN 514891

## Replacement of Parts (Boiler Burner)

### TO FIT NEW BURNER

SEE FIG. 20

1. Remove manifold and fan as shown previously.
2. The burner can now be simply pulled out.

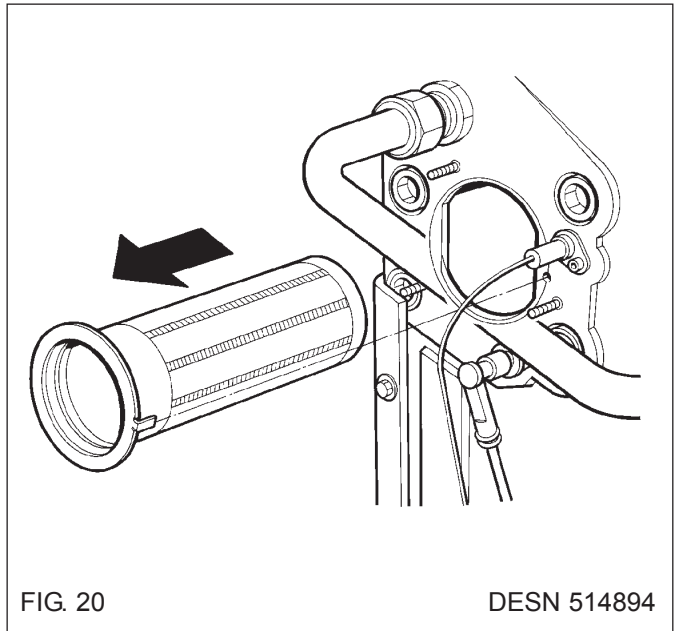

FIG. 20

DESN 514894

### TO FIT NEW IGNITOR, IONISATION PROBE AND OVERHEAT

SEE FIG. 21

1. Remove the 5mm cap screw and pull out the probe.
2. Disconnect the wire from the service block.
3. Withdraw the probe and replace.

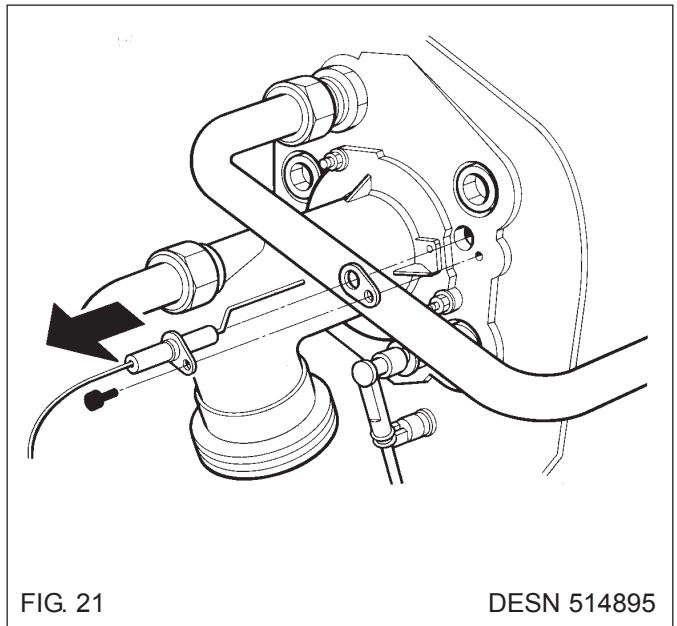

FIG. 21

DESN 514895

### ELECTRODE REPLACEMENT

SEE FIG. 22

1. Disconnect the HT plug.
2. Unscrew 2 x M5 cap screws.
3. Remove electrode from heat exchanger.

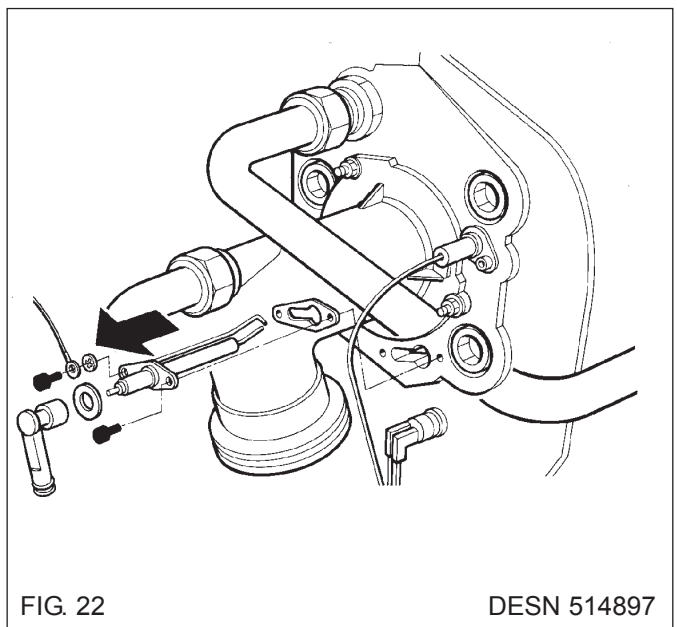

FIG. 22

DESN 514897

## Replacement of Parts (Boiler Burner)

### OVERHEAT STAT REMOVAL

SEE FIG. 23

1. Disconnect 2 flag connectors from the stat.
2. Unscrew overheats and remove.

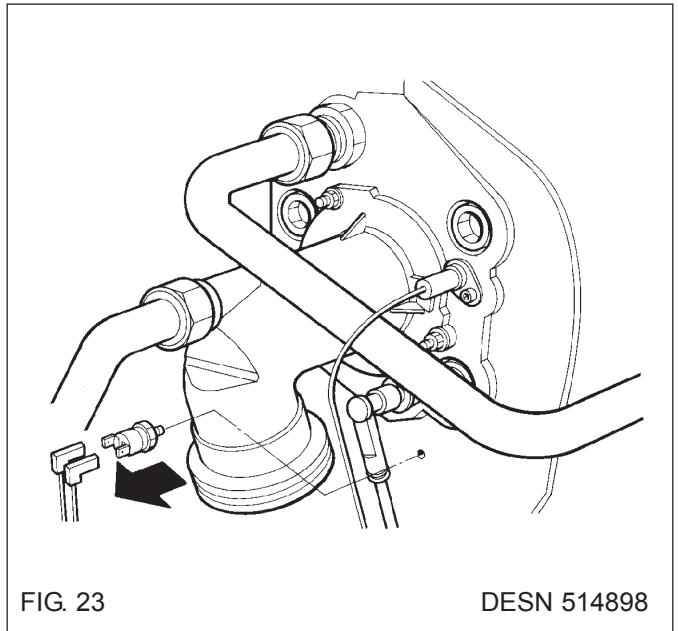

### REMOVAL OF HEAT EXCHANGER ACCESS PANEL AND CLEANING

SEE FIG. 24

1. Unscrew 4 x M6 nuts.
2. Brush and deposits away with a suitable brush.

### EXAMINATION OF HEAT EXCHANGER TRAY

Remove 6mm nut (23) the tray should now drop at the front. **DO NOT** remove the tray, simply check that the tray is clean and not full of deposits. If the tray is deposit-free, lift tray back into position and re-fit the nut to clamp the tray in position.

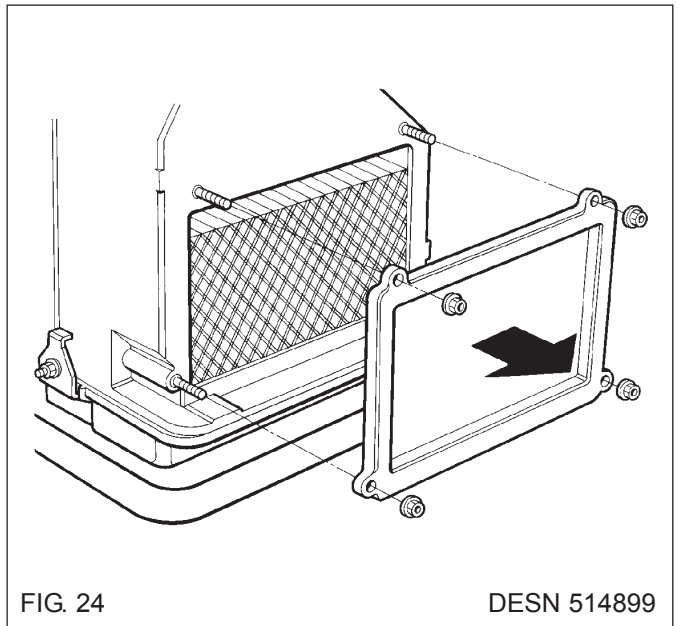

## Replacement of Parts (Boiler Burner)

### REPLACEMENT FLOW/RETURN SENSOR & WATER PRESSURE SWITCH

SEE FIG. 25 & 26

1. To replace the flow and return sensor disconnect the electrical connection and then unclip from the pipe. (See Fig. 25).
2. To replace the water pressure switch, the system must first be drained.
3. Disconnect 2 electrical connectors before unscrewing the switch.

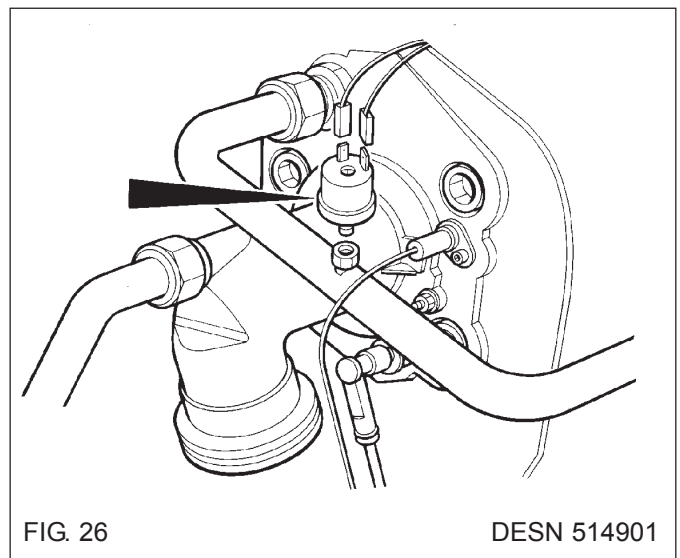
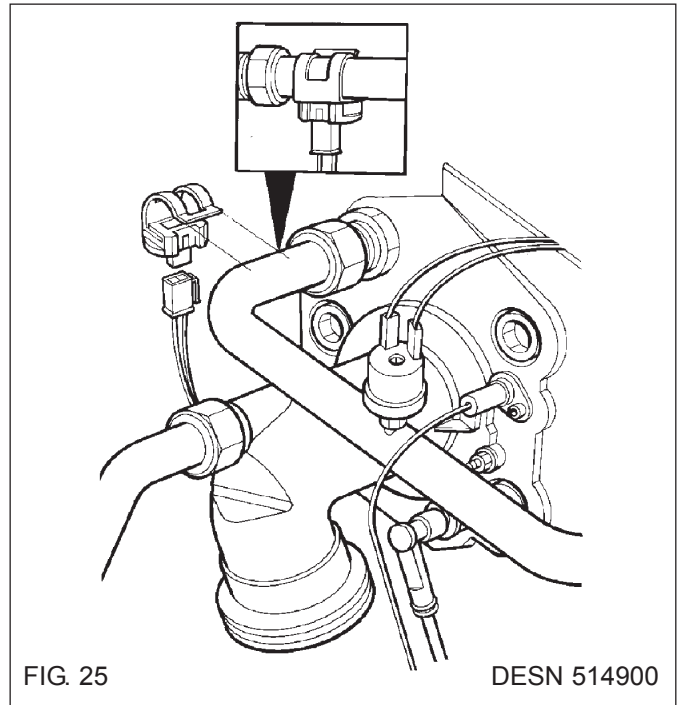

# Fault Diagnostics

Cooker fault code is shown on R.H. side of screen

Boiler fault code is shown on L.H. side of screen

Code	Error	Possible Cause	Correction
A1	No ignition on cooker burner after 3 attempts	<ul style="list-style-type: none"> <li>a. Ignition wire/plug has become detached or is broken.</li> <li>b. No current is being received from ionisation probe.</li> <li>c. Gas valve is not allowing any gas to the burner/throttle is not correctly set.</li> <li>d. Air proving rubber tube (from valve to air inlet tubing has become detached or is ripped).</li> <li>e. Burner fan is not operating correctly.</li> <li>f. Blocked flue and/or air inlet.</li> </ul>	<ul style="list-style-type: none"> <li>a. Check both wiring and plug for faults.</li> <li>b. Remove link wire from ionisation block and check for <math>\mu A</math> reading during ignition.</li> <li>c. Check electrical connector is fitted to the valve and the solenoid open during ignition.</li> <li>d. Check rubber tube is connected properly and there are no tears.</li> <li>e. Ensure connections to fan are made and it is running during ignition attempts.</li> <li>f. Inspect flue/air inlet for any blockages throughout the system.</li> </ul>
A2	No ignition on boiler burner after 3 attempts	<ul style="list-style-type: none"> <li>a. Ignition wire/plug has become detached or is broken.</li> <li>b. No current is being received from ionisation probe.</li> <li>c. Blocked condensate trap/pipe earthing ionisation probe.</li> <li>d. Gas valve is not allowing any gas to the burner/throttle is not correctly set.</li> <li>e. Air proving rubber tube (from valve to fan has become detached or is ripped).</li> <li>f. Blocked flue and/or air inlet.</li> </ul>	<ul style="list-style-type: none"> <li>a. Check both wire and plug for faults.</li> <li>b. Remove link wire from ionisation block and check for <math>\mu A</math> reading during ignition.</li> <li>c. Unscrew condensate trap base, only a small amount of water should escape otherwise a blockage is likely.</li> <li>d. Check electrical connector is fitted to the valve and the solenoid opens during ignition.</li> <li>e. Check rubber tube is connected properly and there are no tears.</li> <li>f. Inspect flue/air inlet for any blockages throughout the system.</li> </ul>
A3	Boiler Overheat Error/ Pressure Sensor Error	<ul style="list-style-type: none"> <li>a. Heating system below required pressure (1 bar) or above required pressure (3 bar).</li> <li>b. Pressure stat not wired correctly/faulty stat.</li> <li>c. Overheat thermocouple triggered on heat exchanger body. (Usually caused by air lock after refilling or by faulty pump).</li> </ul>	<ul style="list-style-type: none"> <li>a. Heating system not pressurised correctly/open system being used.</li> <li>b. Check wiring/wire out stat to determine whether faulty.</li> <li>c. Ensure pump is running and all air is removed from system/wire out stat to determine whether faulty.</li> </ul>
A4	Overheat on cooker	<ul style="list-style-type: none"> <li>a. Oven temperature found to be <math>&gt;270^{\circ}C</math></li> </ul>	<ul style="list-style-type: none"> <li>a. Check cooker flue for blockage/replace cooker thermistors.</li> </ul>
A5	Differential between the 2 cooker thermistors $>20^{\circ}C$ for longer than 10 minutes	<ul style="list-style-type: none"> <li>a. Sensors not fitted correctly/faulty.</li> </ul>	<ul style="list-style-type: none"> <li>a. Ensure thermistors are fitted correctly/replace sensors.</li> </ul>
A6	Boiler fan error	<ul style="list-style-type: none"> <li>a. Wiring connector not fitted correctly/faulty fan.</li> </ul>	<ul style="list-style-type: none"> <li>a. Check connections/replace fan.</li> </ul>
A8	Appliance control board settings incorrect	<ul style="list-style-type: none"> <li>a. Incorrectly installed software in manufacture</li> </ul>	<ul style="list-style-type: none"> <li>a. Reprogram control board with correct software/replace PCB.</li> </ul>

<b>Code</b>	<b>Error</b>	<b>Possible Cause</b>	<b>Correction</b>
<b>A9</b>	Internal Board Error	<ul style="list-style-type: none"> <li>a. Wiring incorrectly installed on site.</li> <li>b. PCB manufacturing unit.</li> </ul>	<ul style="list-style-type: none"> <li>a. Check wiring loom/replace PCB</li> </ul>
<b>E1</b>	Shorted/Open flow sensor	<ul style="list-style-type: none"> <li>a. Connection fault/faulty thermocouple.</li> </ul>	<ul style="list-style-type: none"> <li>a. Check wiring connection/replace stat.</li> </ul>
<b>E2</b>	Cooker thermistor T1 Open/Shorted	<ul style="list-style-type: none"> <li>a. Connection fault/faulty thermistor.</li> </ul>	<ul style="list-style-type: none"> <li>a. Check wiring connection/replace stat.</li> </ul>
<b>E3</b>	Cooker thermistor T2 Open/Shorted	<ul style="list-style-type: none"> <li>a. Connection fault/faulty thermistor.</li> </ul>	<ul style="list-style-type: none"> <li>a. Check wiring connection/replace stat.</li> </ul>
<b>E4</b>	Mains error	<ul style="list-style-type: none"> <li>a. Live and Neutral incorrectly fitted.</li> <li>b. Bad earth connection.</li> <li>c. Incorrect mains frequency.</li> </ul>	<ul style="list-style-type: none"> <li>a. Check wiring.</li> <li>b. Check wiring.</li> <li>c. Check supply frequency.</li> </ul>
<b>E5</b>	Boiler unexpected flame detected	<ul style="list-style-type: none"> <li>a. Possible wiring error.</li> <li>b. Possible gas leak.</li> </ul>	<ul style="list-style-type: none"> <li>a. Check all electrical connections.</li> <li>b. Check all gas connections.</li> </ul>
<b>E6</b>	Cooker unexpected flame detected	<ul style="list-style-type: none"> <li>a. Possible wiring error.</li> <li>b. Possible gas leak</li> </ul>	<ul style="list-style-type: none"> <li>a. Check all electrical connections.</li> <li>b. Check all gas connections.</li> </ul>
<b>E9</b>	Internal board error	<ul style="list-style-type: none"> <li>a. Manufacturing fault.</li> </ul>	<ul style="list-style-type: none"> <li>a. Check wiring/replace board.</li> </ul>











For further advice or information contact your  
local distributor/stockist

With Aga's policy of continuous product  
improvement, the Company reserves the right to  
change specifications and make modifications to  
the appliance described at any time.



Made by  AGA

Manufactured by  
Aga  
Station Road  
Ketley Telford  
Shropshire TF1 5AQ  
England

[www.rayburn-web.co.uk](http://www.rayburn-web.co.uk)  
[www.agacookshop.co.uk](http://www.agacookshop.co.uk)  
[www.agalinks.com](http://www.agalinks.com)